

Controllable Text Generation

Should machines reflect the way humans interact in society?

Shrimai Prabhumoye



Carnegie Mellon University

Language Technologies Institute

Current Systems don't control Style



Current Systems don't control Style

I have a talk to present today!

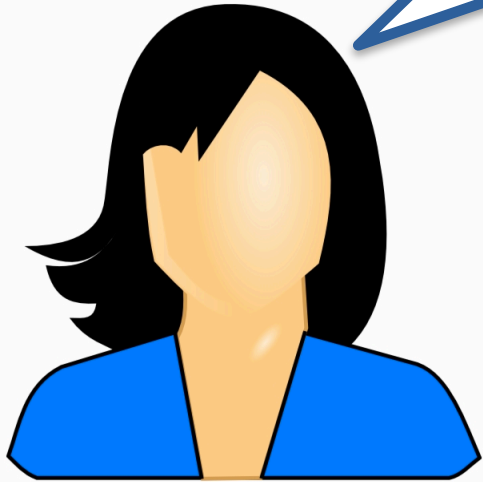

Current Systems don't control Style

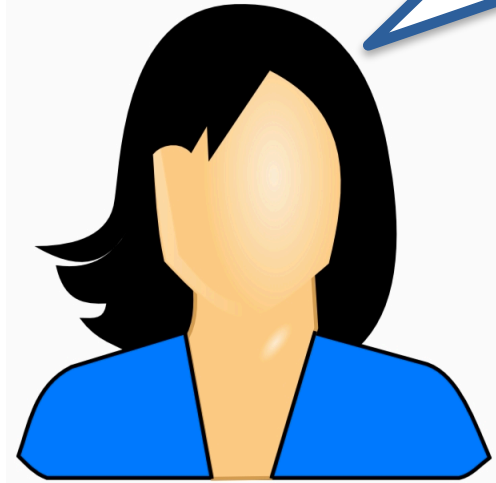

I have a talk to present today!

Best of luck!



Current Systems don't control Style

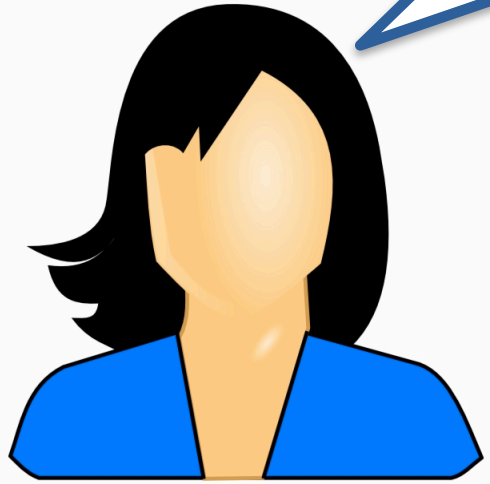

I have a talk to present today!



Best of luck!

Style

Current Systems don't control Style

I have a talk to present today!



May the force be with you!



Style



Current Systems don't control Content

Hey, have you watched
Wonder Woman?

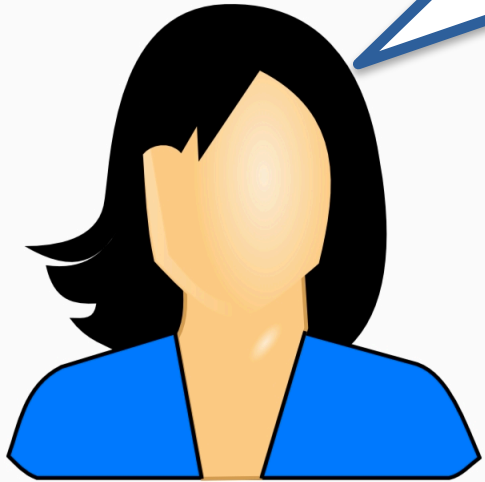

Current Systems don't control Content

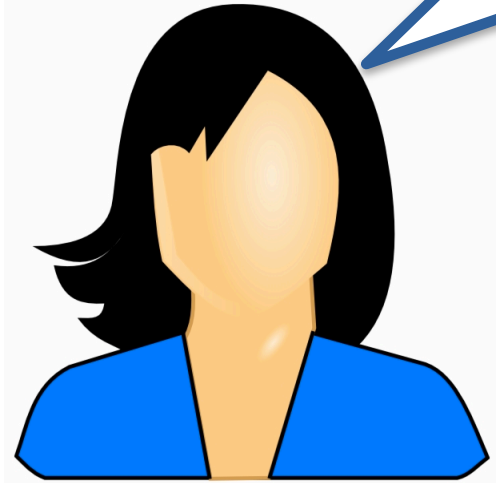

Hey, have you watched
Wonder Woman?

Yeah, I loved Brie
Larson in it!



Current Systems don't control Content

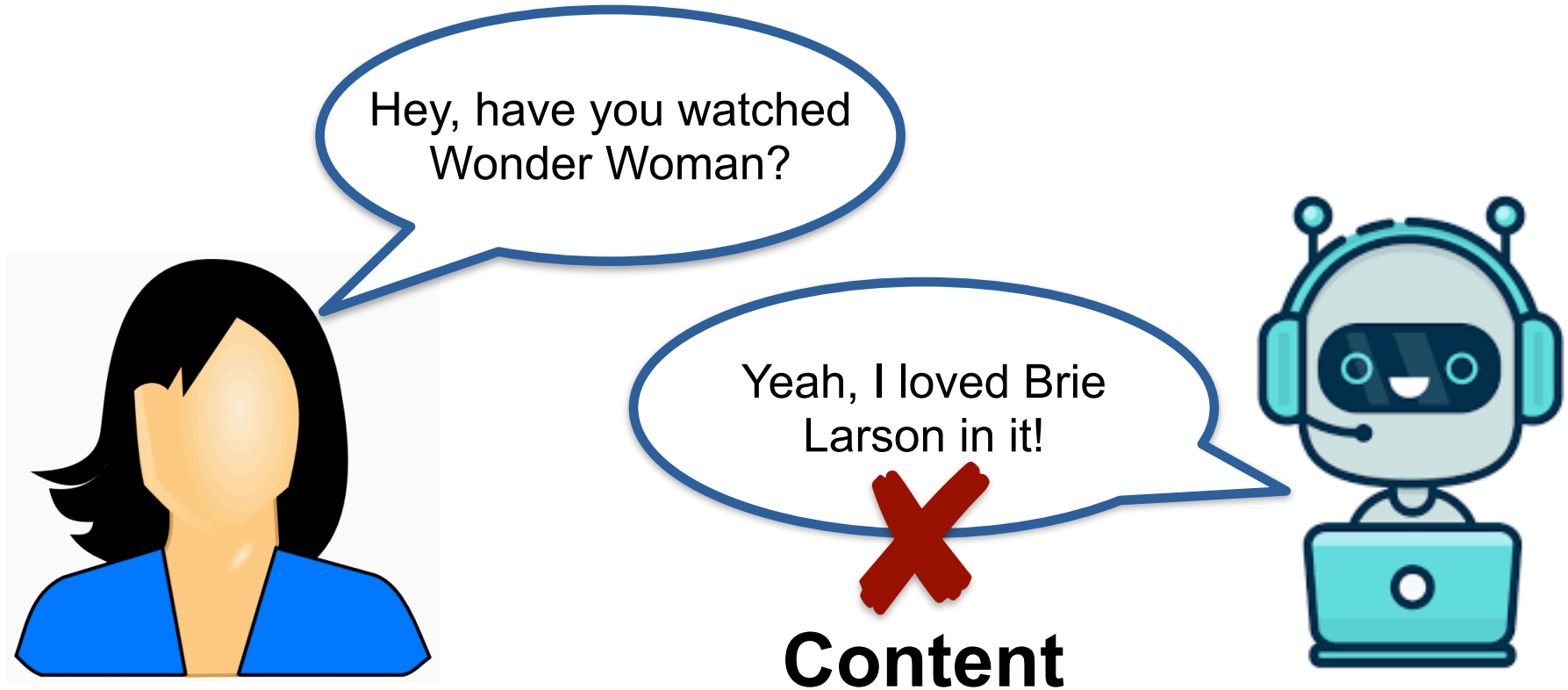

Current Systems don't control Content

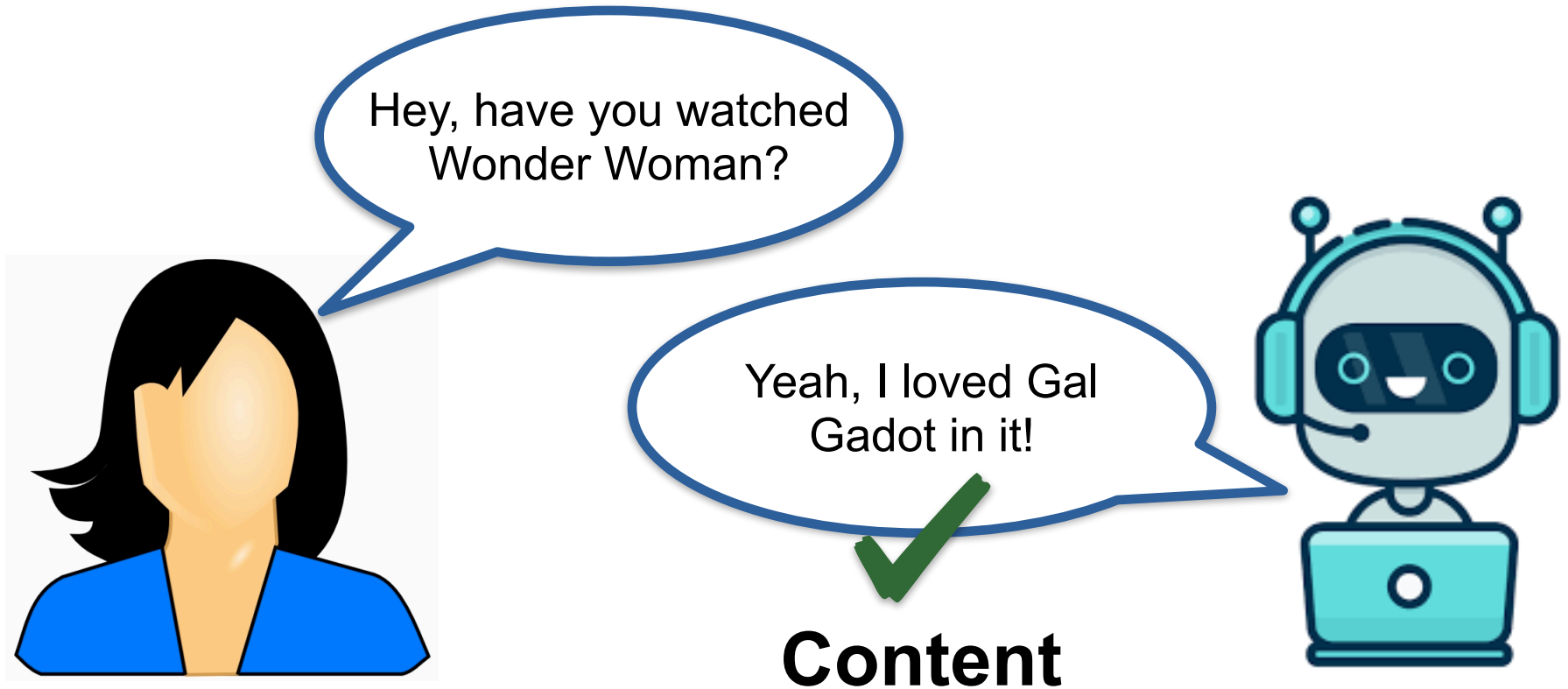

Current Systems don't control Structure

Tell me the story of Avengers Endgame!



Current Systems don't control Structure

Tell me the story of Avengers Endgame!

Yeah, Ironman steals the
Infinity Stones back from Thanos
...
Ironman builds a time machine to
save the world.



Current Systems don't control Structure

Tell me the story of Avengers Endgame!



Structure

Yeah, Ironman steals the
Infinity Stones back from Thanos
...
Ironman builds a time machine to
save the world.



Current Systems don't control Structure

Tell me the story of Avengers Endgame!



✓
Yeah, Thor decapitates Thanos
...
Ironman steals the Infinity Stones back from Thanos

Structure



GPT-2 cannot control style and content



Write With Transformer `gpt2` ⓘ



Shuffle initial text



Trigger autocomplete or `tab`

Select suggestion `↑` `↓` and `enter`

Can you tell me the story of Avengers Endgame? Did you get a chance to play it when it was released?

Mitch: It

I know you are very busy

I got to play

Who was your favorite in Tenet? I really liked the way he was able to

get people to care and really get

pull off a game plan.

get away with things, the way

Can you tell me the different ways of saying 'Please be quiet.'? How many ways? What's the difference

between

?

Can you tell me the story of Tenet? How did he get his job as the director of the CIA? ←←←He

of the CIA in 1997 when his

of the CIA? Did he

NLP Applications are on the rise!

NLP Applications are on the rise!

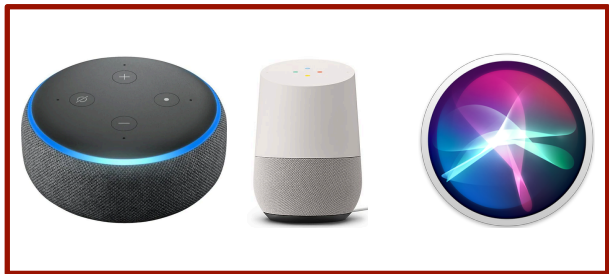

Personal Assistants

NLP Applications are on the rise!

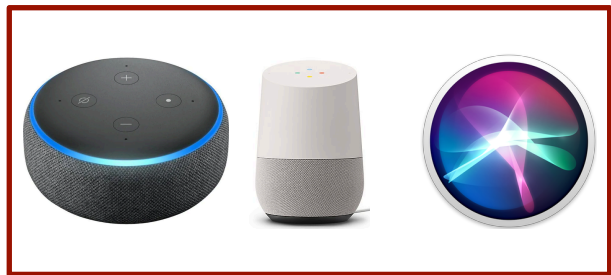

Personal Assistants

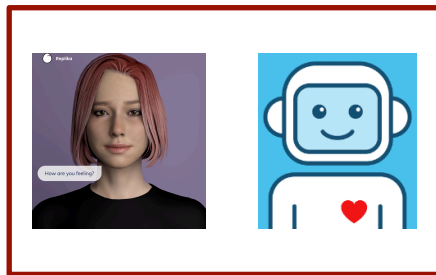

Empathy/Compassion bots

NLP Applications are on the rise!

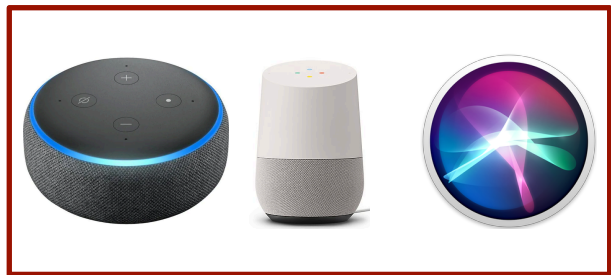

Personal Assistants

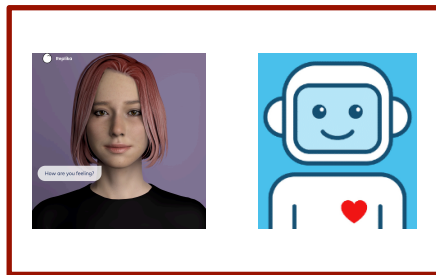

Empathy/Compassion bots



Call-center/FAQ bots

NLP Applications are on the rise!

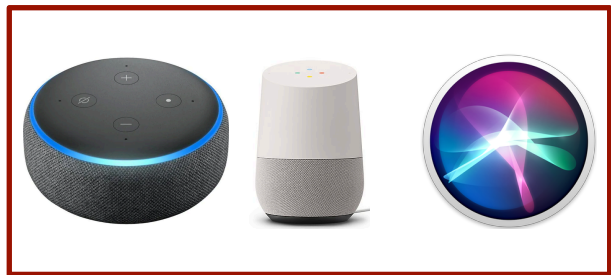

Personal Assistants

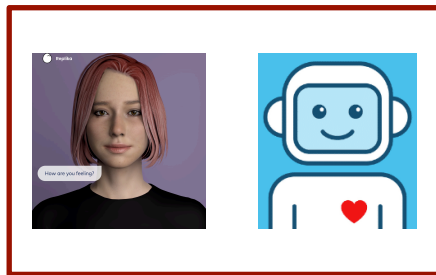

Empathy/Compassion bots



Call-center/FAQ bots



Ubiquitous Computing

NLP Applications are on the rise!

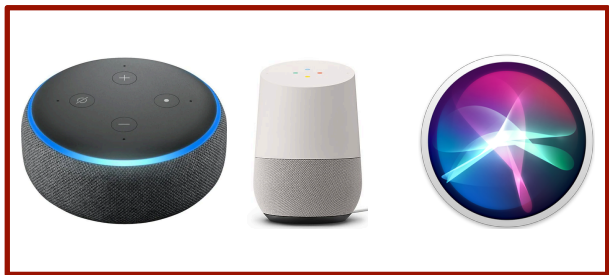

Personal Assistants

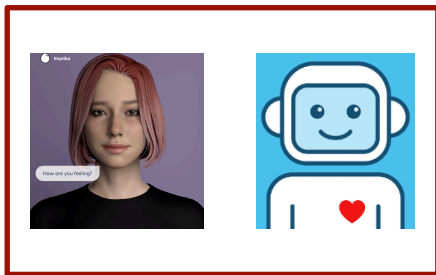

Empathy/Compassion bots

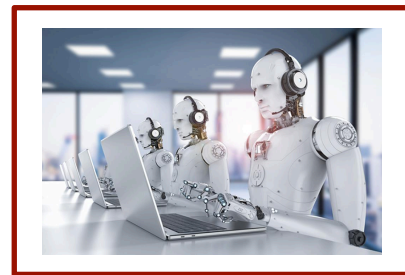

Call-center/FAQ bots



Ubiquitous Computing



Other Applications

NLP Applications are on the rise!

- Style of responses
- Persona of the bot
- Topic of responses

Personal Assistants

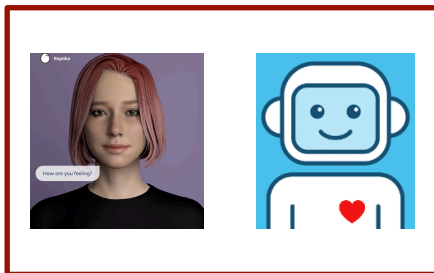

Empathy/Compassion bots

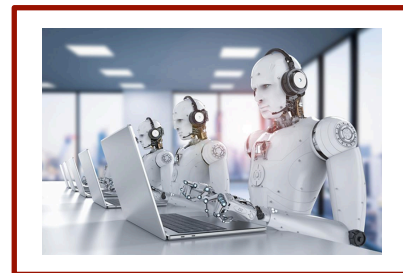

Call-center/FAQ bots



Ubiquitous Computing



Other Applications

NLP Applications are on the rise!

- Style of responses
- Persona of the bot
- Topic of responses

Personal Assistants

- Emotions (style)
- Sensitivity of content

Empathy/Compassion bots



Call-center/FAQ bots



Ubiquitous Computing



Other Applications

NLP Applications are on the rise!

- Style of responses
- Persona of the bot
- Topic of responses

Personal Assistants

- Emotions (style)
- Sensitivity of content

Empathy/Compassion bots

- Content needs to be accurate!
- Structured/
Unstructured data

Call-center/FAQ bots



Ubiquitous Computing



Other Applications

NLP Applications are on the rise!

- Style of responses
- Persona of the bot
- Topic of responses

Personal Assistants

- Emotions (style)
- Sensitivity of content

Empathy/Compassion bots

- Content needs to be accurate!
- Structured/
Unstructured data

Call-center/FAQ bots

- Accurate information
- Structured data

Ubiquitous Computing



The image shows a screenshot of an email conversation on the left and a stylized 'NLP' logo on the right. The email is from 'manager@empathy.com' to 'jane@empathy.com' with the subject 'Data for Impact...'. The email body contains a question about user experience and a response from 'Jane' asking for more details. The 'NLP' logo is rendered in a pixelated, blocky font. To the right of the logo is a green circular icon with a white arrow pointing clockwise, representing a refresh or update action.

Other Applications

NLP Applications are on the rise!

- Style of responses
- Persona of the bot
- Topic of responses

Personal Assistants

- Emotions (style)
- Sensitivity of content

Empathy/Compassion bots

- Content needs to be accurate!
- Structured/
Unstructured data

Call-center/FAQ bots

- Accurate information
- Structured data

Ubiquitous Computing

- Plot of stories (structure)
- Sequence of topics in stories (structure)
- Politeness of emails (style)

Other Applications

**The key to human-like generation
is**

The key to human-like generation is

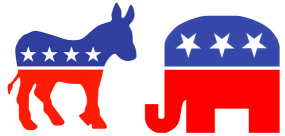

Style



Content

First of all, i did not expect to come into a cafeteria style eatery.

They serve the basics of bbq, nothing too fancy.

A few appetizers and side options, like cheesy potatoes, fresh corn bread, etc.

All were very tasty.

Overall, this is a great place.

Structure

Style is “how” an intent is expressed

- Expressed in the choice of *words or phrases* as well as *syntactic structures* used to convey information

(Coupland, CUP 2007; Eckert, Language 2019; Hovy, JOP 1987; Hu et al, ICML 2017; Shen et al, NeurIPs 2017; Li et al, NAACL 2018; Prabhumoye et al, ACL 2018; Fu et al, AACL 2018; John et al, ACL 2019; Sudhakar et al, EMNLP-IJCNLP 2019; Madaan et al, ACL 2020)



“Do you have any code that we can look at?”



“Any code? Or do I have to guess at how you did it?”

Content is “what” is to be conveyed

- Communication: individuals *exchange information* and influence one another through a common system of symbols and signs.
- Leverage information in the unstructured form

(Liu et al, ICLR 2018; Zhou et al, EMNLP 2018; Ghazviinejad et al, AAAI 2018; Dinan et al, ICLR 2019; Prabhunoye et al, NAACL 2019)



Wikipedia



Gutenberg

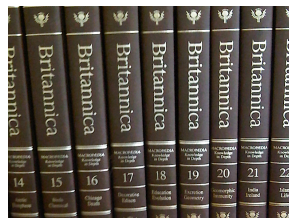

Encyclopedia



Internet

Structure is ordering of information

- Communication is well *planned* and structured
- Sentence ordering: *ordering* of information

1

[Obama Birth & 44th president]

Barack Hussein Obama II (born August 4, 1961) ... 44th president of the US from 2009 to 2017.

3

[Previously an Illinois senator]

He previously served as a US senator from Illinois from 2005 to 2008 ...

2

[Democrat, first African-American president]

A member of the Democratic party, Obama was the first African-American president of the US.

2

[Democrat, first African-American president]

A member of the Democratic party, Obama was the first African-American president of the US.

3

[Previously an Illinois senator]

He previously served as a US senator from Illinois from 2005 to 2008 ...

1

[Obama Birth & 44th president]

Barack Hussein Obama II (born August 4, 1961) ... 44th president of the US from 2009 to 2017.

Overview



Style

ACL '20
Storytelling '19
ACL '18



Content

NAACL '21
NAACL '19
EMNLP '18



Structure

ACL '20

Control Attributes

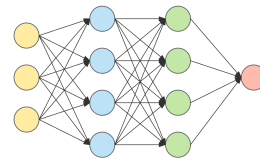

Modeling

COLING '20

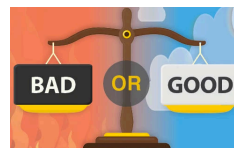

Ethics

NAACL '21
chap. in L.L.C '21
WinLP '19

Common Themes

Overview



Style

ACL '20
Storytelling '19
ACL '18

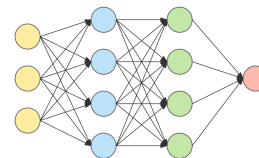

COLING '20

Modeling



Content

NAACL '21
NAACL '19
EMNLP '18

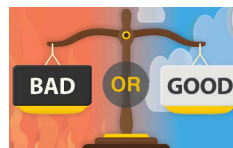

NAACL '21
chap. in L.L.C '21
WiNLP '19

Ethics



Structure

ACL '20

Control Attributes

Common Themes

Overview



Style

ACL '20
Storytelling '19
ACL '18



Content

NAACL '21
NAACL '19
EMNLP '18



Structure

ACL '20

Control Attributes

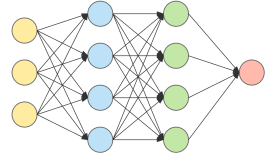

Modeling

COLING '20

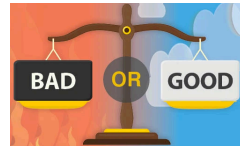

Ethics

NAACL '21
chap. in L.L.C '21
WinLP '19

Common Themes

Overview

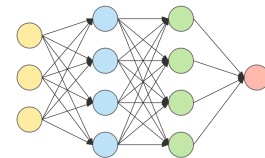

COLING '20

Modeling

Overview

- Schema of five modules
- Organize prior work
- Understand techniques to add control

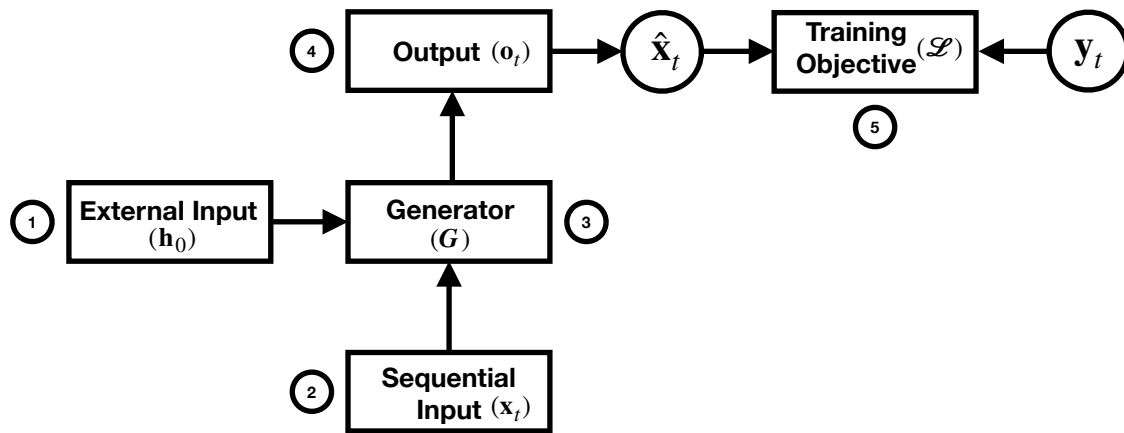
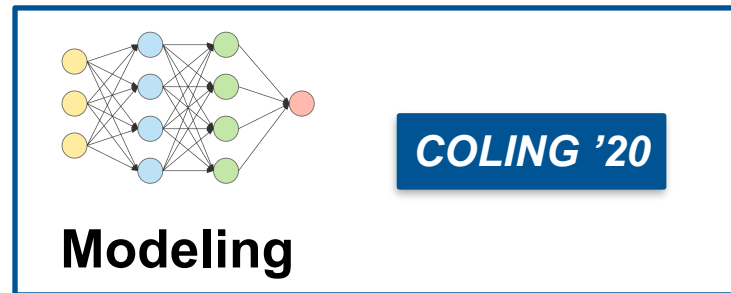

Overview



Style

ACL '20
Storytelling '19
ACL '18



Content

NAACL '21
NAACL '19
EMNLP '18



Structure

ACL '20

Control Attributes

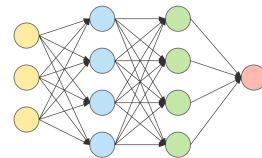

Modeling

COLING '20

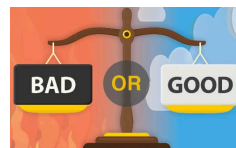

Ethics

NAACL '21
chap. in L.L.C '21
WinNLP '19

Common Themes

Overview

- Constraint Solving Problem vs Sequence Prediction Task
- Learn constraints using BERT
- Topological sort to find an order given constraints



ACL '20

Structure

Overview



Style

ACL '20
Storytelling '19
ACL '18



Content

NAACL '21
NAACL '19
EMNLP '18



Structure

ACL '20

Control Attributes

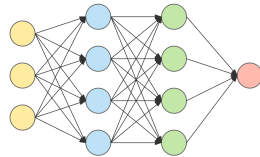

Modeling

COLING '20

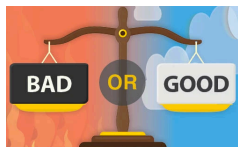

Ethics

NAACL '21
chap. in L.L.C '21
WinLP '19

Common Themes

What is Style Transfer?

- Rephrasing the text to contain specific stylistic properties without changing the intent or affect within the context.

What is Style Transfer?

- Rephrasing the text to contain specific stylistic properties without changing the intent or affect within the context.

“Shut up! the video is starting!”

“Please be quiet, the video will begin shortly.”

Challenges in style transfer

Challenges in style transfer

- Style is *culturally diverse*

Usage of “please”
to closest friends.



Challenges in style transfer

- Style is *culturally diverse*
- Style is *subtle*

Indirect: By the way, do you know when is the deadline?

1st person plural: Let us find a good name for this paper.

Challenges in style transfer

- Style is *culturally diverse*
- Style is *subtle*
- *Disentangle* style and content

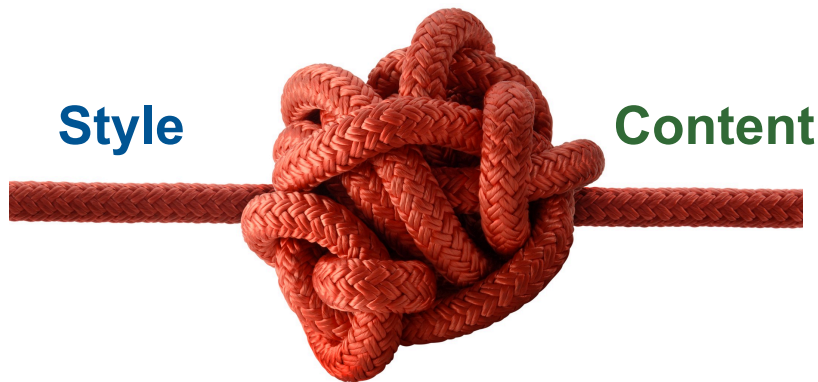

Challenges in style transfer

- Style is *culturally diverse*
- Style is *subtle*
- *Disentangle* style and content
- *Lack* of parallel data



Style Transfer

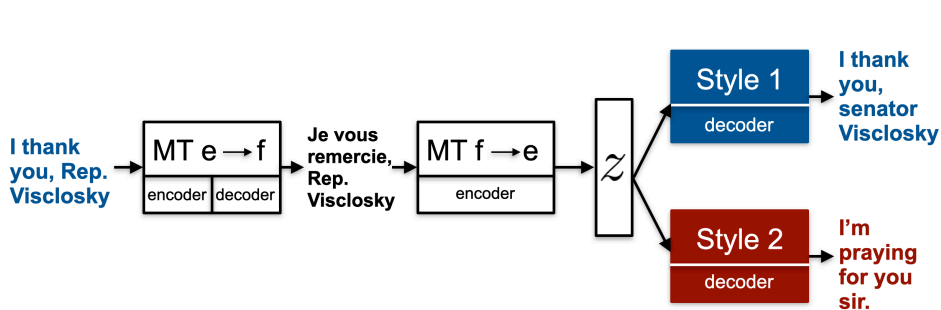

Back-Translation Style Transfer [ACL, 2018]

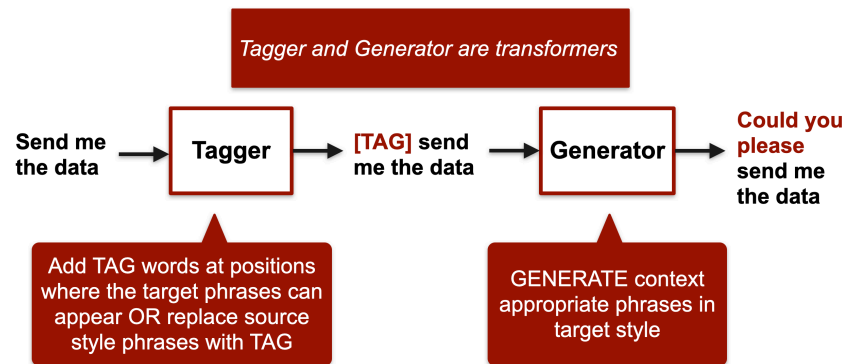

Tag and Generate [ACL, 2020]

- Two novel approaches for style transfer
- Political slant transfer and Politeness transfer

Overview



Style

ACL '20
Storytelling '19
ACL '18



Content

NAACL '21
NAACL '19
EMNLP '18



Structure

ACL '20

Control Attributes

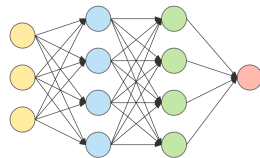

Modeling

COLING '20

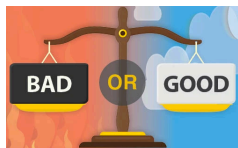

Ethics

NAACL '21
chap. in L.L.C '21
WinLP '19

Common Themes

Overview



Style

ACL '20
Storytelling '19
ACL '18



Content

NAACL '21
NAACL '19
EMNLP '18



Structure

ACL '20

Control Attributes

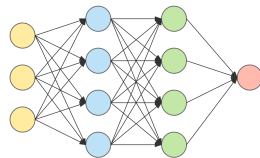

Modeling

COLING '20

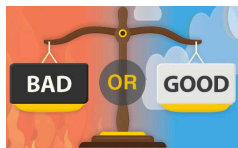

Ethics

NAACL '21
chap. in L.L.C '21
WinNLP '19

Common Themes

Overview



Style

ACL '20
Storytelling '19
ACL '18



Content

NAACL '21
NAACL '19
EMNLP '18



Structure

ACL '20

Control Attributes

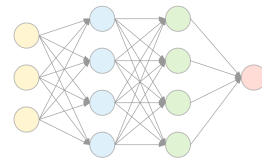

Modeling

COLING '20

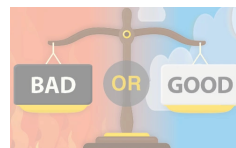

Ethics

NAACL '21
chap. in L.L.C '21
WinNLP '19

Common Themes

Document Grounded Generation

Document Grounded Generation



Context

Document Grounded Generation



Context

+



Document

Document Grounded Generation



Context

+

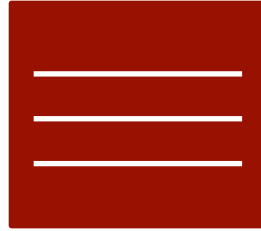

Document

=

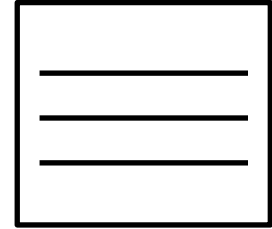

Updated Text

Document Grounded Generation



- generate text given a context and a document
- generated text should *coherently fit* the context and contain new information from the document

Wikipedia Update Generation

Wikipedia Update Generation



WIKIPEDIA
The Free Encyclopedia

Not logged in | Talk | Contributions | Create account | Log in

Article | **Talk** | Read | Edit | View history | Search Wikipedia

Monkey selfie copyright dispute

From Wikipedia, the free encyclopedia

The **monkey selfie copyright dispute** is a series of disputes about the [copyright](#) status of [selfies](#) taken by [Celebes crested macaques](#) using equipment belonging to the British nature photographer David Slater. The disputes involve [Wikimedia Commons](#) and the blog *Techdirt*, which have hosted the images following their publication in newspapers in July 2011 over Slater's objections that he holds the copyright, and [People for the Ethical Treatment of Animals](#) (PETA), who have argued that the macaque should be assigned the copyright.

Slater has argued that he has a valid copyright claim, as he engineered the situation that resulted in the pictures by travelling to Indonesia, befriending a group of wild macaques, and setting up his camera equipment in such a way that a "selfie" picture might come about. The [Wikimedia Foundation's](#) 2014 refusal to remove the pictures from its Wikimedia Commons image library was based on the understanding that copyright is held by the creator, that a non-human creator (not being a [legal person](#)) cannot hold copyright, and that the images are thus in the [public domain](#).



One of the monkey selfies at issue

Navigation links: Main page, Contents, Current events, Random article, About Wikipedia, Contact us, Donate, Contribute, Help, Community portal, Recent changes, Upload file, Tools, What links here, Related changes, Special pages.

Wikipedia Update Generation



WIKIPEDIA
The Free Encyclopedia

- Main page
- Contents
- Current events
- Random article
- About Wikipedia
- Contact us
- Donate

- Contribute
- Help
- Community portal
- Recent changes
- Upload file

- Tools
- What links here
- Related changes
- Social pages

Not logged in [Talk](#) [Contributions](#) [Create account](#) [Log in](#)

Article [Talk](#)

Read [Edit](#) [View history](#)

Monkey selfie copyright dispute

From Wikipedia, the free encyclopedia

The **monkey selfie copyright dispute** is a series of disputes about the [copyright](#) status of [selfies](#) taken by [Celebes crested macaques](#) using equipment belonging to the British nature photographer David Slater. The disputes involve [Wikimedia Commons](#) and the blog *Techdir*, which have hosted the images following their publication in newspapers in July 2011 over Slater's objections that he holds the copyright, and [People for the Ethical Treatment of Animals](#) (PETA), who have argued that the macaque should be assigned the copyright.

Slater has argued that he has a valid copyright claim, as he engineered the situation that resulted in the pictures by travelling to Indonesia, befriending a group of wild macaques, and setting up his camera equipment in such a way that a "selfie" picture might come about. The [Wikimedia Foundation's](#) 2014 refusal to remove the pictures from its Wikimedia Commons image library was based on the understanding that copyright is held by the creator, that a non-human creator (not being a [legal person](#)) cannot hold copyright, and that the images are thus in the [public domain](#).



One of the monkey selfies at issue

Amateur Photographer

Subscribe now Digital

Latest Opinion Reviews How To Inspiration AP Awards The Video Mode

Home / Latest / Latest news

Ape-rture priority photographer plays down monkey reports

Chris Cheesman
July 5, 2011

0 shares

A photographer who says he witnessed monkeys taking pictures of themselves, tells Amateur Photographer (AP) that much of the media coverage has been exaggerated.

Wildlife photographer David Slater today played down newspaper reports that suggest a bunch of Indonesian monkeys grabbed his camera and began taking self-portraits.

And he revealed that the shots, featuring the endangered crested black macaque monkey, were taken three years ago.

Speaking to AP, David explained that his camera had been mounted on a tripod when the primates

Latest reviews

Leica M10-R review

Andy Westlake takes a detailed look at Leica's latest high-resolution...



Canon EOS R6 review: hands-on first look

Look out Sony - Canon may just have got full-



Wikipedia Update Generation



WIKIPEDIA
The Free Encyclopedia

Not logged in | Talk | Contributions | Create account | Log in

Article | Talk | Read | Edit | View history | Search Wikipedia

Monkey selfie copyright dispute

From Wikipedia, the free encyclopedia

The **monkey selfie copyright dispute** is a series of disputes about the **copyright** status of **selfies** taken by **Celebes crested macaques** using equipment belonging to the British nature photographer David Slater. The disputes involve **Wikimedia Commons** and the blog *Techdirt*, which have hosted the images following their publication in newspapers in July 2011 over Slater's objections that he holds the copyright, and **People for the Ethical Treatment of Animals** (PETA), who have argued that the macaque should be assigned the copyright.

Slater has argued that he has a valid copyright claim, as he engineered the situation that resulted in the pictures by travelling to Indonesia, befriending a group of wild macaques, and setting up his camera equipment in such a way that a "selfie" picture might come about. The **Wikimedia Foundation's** 2014 refusal to remove the pictures from its **Wikimedia Commons** image library was based on the understanding that copyright is held by the creator, that a non-human creator (not being a **legal person**) cannot hold copyright, and that the images are thus in the **public domain**.



One of the monkey selfies at issue

The following day, *Amateur Photographer* reported that Slater gave them further explanation as to how the photographs were created, downplaying the way newspaper articles had described them; Slater said reports that a monkey ran off with his camera and "began taking self-portraits" were incorrect and that the portrait was shot when his camera had been mounted on a tripod, with the primates playing around with a remote cable release as he fended off other monkeys.^[13]



Amateur Photographer

Subscribe now Digital

Home | Latest | Opinion | Reviews | How To | Inspiration | AP Awards | The Video Mode

Home / Latest / Latest news

Ape-rture priority photographer plays down monkey reports

Chris Cheesman
July 5, 2011

0 shares

A photographer who says he witnessed monkeys taking pictures of themselves, tells Amateur Photographer (AP) that much of the media coverage has been exaggerated.

Wildlife photographer David Slater today played down newspaper reports that suggest a bunch of Indonesian monkeys grabbed his camera and began taking self-portraits.

And he revealed that the shots, featuring the endangered crested black macaque monkey, were taken three years ago.

Speaking to AP, David explained that his camera had been mounted on a tripod when the primates

Latest reviews

Leica M10-R review

Andy Westlake takes a detailed look at Leica's latest high-resolution...

Canon EOS R6 review: hands-on first look

Look out Sony - Canon may just have got full-

Wikipedia Update Generation



WIKIPEDIA
The Free Encyclopedia

Not logged in | Talk | Contributions | Create account | Log in

Article | Talk | Read | Edit | View history | Search Wikipedia

Monkey selfie copyright dispute

From Wikipedia, the free encyclopedia

The **monkey selfie copyright dispute** is a series of disputes about the **copyright** status of **selfies** taken by **Celebes crested macaques** using equipment belonging to the British nature photographer David Slater. The disputes involve **Wikimedia Commons** and the blog *Techdirt*, which have hosted the images following their publication in newspapers in July 2011 over Slater's objections that he holds the copyright, and **People for the Ethical Treatment of Animals** (PETA), who have argued that the macaque should be assigned the copyright.

Slater has argued that he has a valid copyright claim, as he engineered the situation that resulted in the pictures by travelling to Indonesia, befriending a group of wild macaques, and setting up his camera equipment in such a way that a "selfie" picture might come about. The **Wikimedia Foundation's** 2014 refusal to remove the pictures from its Wikimedia Commons image library was based on the understanding that copyright is held by the creator, that a non-human creator (not being a **legal person**) cannot hold copyright, and that the images are thus in the **public domain**.



One of the monkey selfies at issue

The following day, *Amateur Photographer* reported that Slater gave them further explanation as to how the photographs were created, downplaying the way newspaper articles had described them; Slater said reports that a monkey ran off with his camera and "began taking self-portraits" were incorrect and that the portrait was shot when his camera had been mounted on a tripod, with the primates playing around with a remote cable release as he fended off other monkeys.^[13]



Amateur Photographer

Subscribe now Digital

Home | Latest | Opinion | Reviews | How To | Inspiration | AP Awards | The Video Mode

Home / Latest / Latest news

Ape-rture priority photographer plays down monkey reports

Chris Cheesman
July 5, 2011

0 shares

A photographer who says he witnessed monkeys taking pictures of themselves, tells Amateur Photographer (AP) that much of the media coverage has been exaggerated.

Wildlife photographer David Slater today played down newspaper reports that suggest a bunch of Indonesian monkeys grabbed his camera and began taking self-portraits.

And he revealed that the shots, featuring the endangered crested black macaque monkey, were taken three years ago.

Speaking to AP, David explained that his camera had been mounted on a tripod when the primates

Latest reviews

Leica M10-R review

Andy Westlake takes a detailed look at Leica's latest high-resolution...

Canon EOS R6 review: hands-on first look

Look out Sony - Canon may just have got full-

Generate text that is:

1. **coherent** to the Wikipedia context
 2. contains **new events** from the article
- Dataset Size of 636k!**

Document Grounded Dialogue

Document Grounded Dialogue

Chat History

Alice: Yes this is a Christmas classic ...

Bob: Very well said! Some of the critics were ...

Alice: Yes I found the first half very entertaining.

Bob: I feel you! So hard to believe it was
released in 1990!

Document Grounded Dialogue

Chat History

Alice: Yes this is a Christmas classic ...

Bob: Very well said! Some of the critics were ...

Alice: Yes I found the first half very entertaining.

Bob: I feel you! So hard to believe it was released in 1990!



WIKIPEDIA
The Free Encyclopedia

Article **Talk**

Home Alone

From Wikipedia, the free encyclopedia

Home Alone is a 1990 American [comedy film](#) written and produced by [John Hughes](#) and directed by [Chris Columbus](#). It stars [Macaulay Culkin](#), [Joe Pesci](#), [Daniel Stern](#), [John Heard](#), and [Catherine O'Hara](#). Culkin stars as eight-year-old Kevin, who defends his home from burglars Harry and Marv (Pesci and Stern) after his family accidentally leaves him behind on their vacation.

Home Alone was filmed between February and May 1990 in locations throughout [Illinois](#). It was originally set to be distributed by [Warner Bros.](#), but transferred to [20th Century Fox](#) when Hughes exceeded Warner's \$10 million budget.

Document



Document Grounded Dialogue

Chat History

Alice: Yes this is a Christmas classic ...

Bob: Very well said! Some of the critics were ...

Alice: Yes I found the first half very entertaining.

Bob: I feel you! So hard to believe it was released in 1990!

Response

Alice: I like the quote "**sadistic festival of adult-bashing**". Between's **Kevin's parents forgetting him and the burglars** this movie doesn't make adult looks too bright.



WIKIPEDIA
The Free Encyclopedia

Article **Talk**

Home Alone

From Wikipedia, the free encyclopedia

Home Alone is a 1990 American **comedy film** written and produced by **John Hughes** and directed by **Chris Columbus**. It stars **Macaulay Culkin**, **Joe Pesci**, **Daniel Stern**, **John Heard**, and **Catherine O'Hara**. Culkin stars as eight-year-old Kevin, who defends his home from burglars Harry and Marv (Pesci and Stern) after his family accidentally leaves him behind on their vacation.

Home Alone was filmed between February and May 1990 in locations throughout **Illinois**. It was originally set to be distributed by **Warner Bros.**, but transferred to **20th Century Fox** when Hughes exceeded Warner's \$10 million budget.

Document



Document Grounded Dialogue

Alice: Yes this is a Christmas classic ...

Bob: Very well said! Some of the critics were ...

Alice: Yes I found the first half very entertaining

Chat History

- Generate response that is:
 1. *coherent* to the dialogue context (chat history)
 2. contains *information* from the document
- CMU Document Grounded Conversations (**CMU_DoG**) Dataset
- Dataset size of **130k utterances!**

Alice: I like the quote "**sadistic festival of adult-bashing**". Between's **Kevin's parents forgetting him and the burglars** this movie doesn't make adult looks too bright.



Home Alone

edia, the free encyclopedia

ican comedy film written and produced by John Columbus. It stars Macaulay Culkin, Joe Pesci, and Catherine O'Hara. Culkin stars as eight-year-old Kevin McCallister, who is left home alone after being forgotten by his parents on their vacation. The film was released in theaters between February and May 1990 in locations originally set to be distributed by Warner Bros., but was eventually distributed by Fox when Hughes exceeded Warner's \$10 million



Document

Models

- Pre-trained encoder-decoder model
 - provide a stronger baseline for the task

Pre-trained Models

DOC

...

Meanwhile, *newspapers across the country pick up the story in solidarity with the post and times*. The court rules 6 3 in the newspapers' favor, vindicating graham's decision. *Nixon demands that the post should be barred from the white house*.

...

One year later, a security guard discovers a break-in progress at watergate complex.

CONTEXT

It was honorable for the *other papers to publish in solidarity with the post and times*. That had to prove that the people want to know.

Pre-trained Models

DOC

...

Meanwhile, *newspapers across the country pick up the story in solidarity with the post and times*. The court rules 6 3 in the newspapers' favor, vindicating graham's decision. *Nixon demands that the post should be barred from the white house.*

...

One year later, a security guard discovers a break-in progress at watergate complex.

CONTEXT

It was honorable for the *other papers to publish in solidarity with the post and times*. That had to prove that the people want to know.

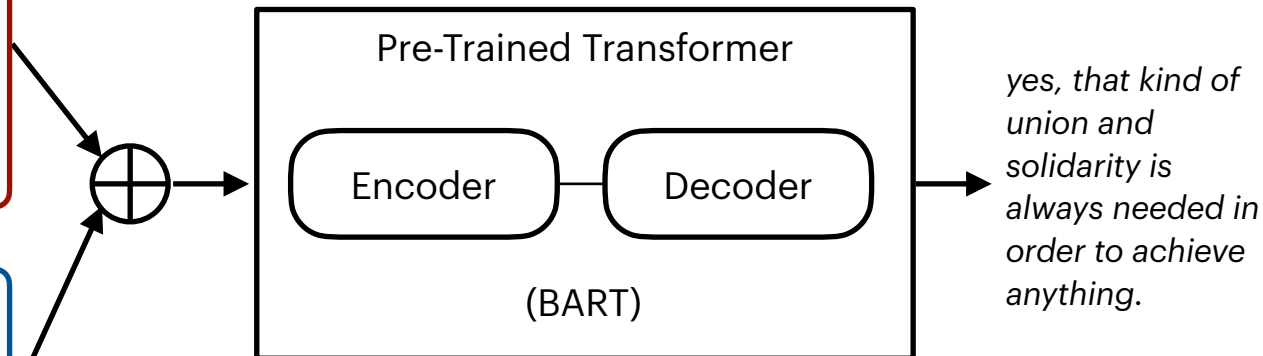

Models

- Pre-trained encoder-decoder model
 - provide a stronger baseline for the task
- Context Driven Representation (CoDR)
 - build a representation of the content in document that is ***not present*** in the context
- Document Headed Attention (DoHA)
 - specific ***focus on document*** information

Context Driven Representation (CoDR)

DOC

...

Meanwhile, *newspapers across the country pick up the story in solidarity with the post and times*. The court rules 6 3 in the newspapers' favor, vindicating graham's decision. *Nixon demands that the post should be barred from the white house*.

...

One year later, a security guard discovers a break-in progress at watergate complex.

CONTEXT

It was honorable for the *other papers to publish in solidarity with the post and times*. That had to prove that the people want to know.

Context Driven Representation (CoDR)

DOC

...

Meanwhile, *newspapers across the country pick up the story in solidarity with the post and times*. The court rules 6 3 in the newspapers' favor, vindicating graham's decision. *Nixon demands that the post should be barred from the white house.*

...

One year later, a security guard discovers a break-in progress at watergate complex.

CONTEXT

It was honorable for the *other papers to publish in solidarity with the post and times*. That had to prove that the people want to know.

Pre-Trained Transformer
Encoder
(BART Encoder)



Context Driven Representation (CoDR)

DOC

...

Meanwhile, *newspapers across the country pick up the story in solidarity with the post and times*. The court rules 6 3 in the newspapers' favor, vindicating graham's decision. *Nixon demands that the post should be barred from the white house*.

...

One year later, a security guard discovers a break-in progress at watergate complex.

CONTEXT

It was honorable for the *other papers to publish in solidarity with the post and times*. That had to prove that the people want to know.

Pre-Trained Transformer
Encoder
(BART Encoder)



h_d



h_c

Context Driven Representation (CoDR)

DOC

...

Meanwhile, *newspapers across the country pick up the story in solidarity with the post and times*. The court rules 6 3 in the newspapers' favor, vindicating graham's decision. *Nixon demands that the post should be barred from the white house*.

...

One year later, a security guard discovers a break-in progress at watergate complex.

CONTEXT

It was honorable for the *other papers to publish in solidarity with the post and times*. That had to prove that the people want to know.

h_d



h_c



Context Driven Representation (CoDR)

DOC

...

Meanwhile, *newspapers across the country pick up the story in solidarity with the post and times*. The court rules 6 3 in the newspapers' favor, vindicating graham's decision. *Nixon demands that the post should be barred from the white house*.

...

One year later, a security guard discovers a break-in progress at watergate complex.

CONTEXT

It was honorable for the *other papers to publish in solidarity with the post and times*. That had to prove that the people want to know.

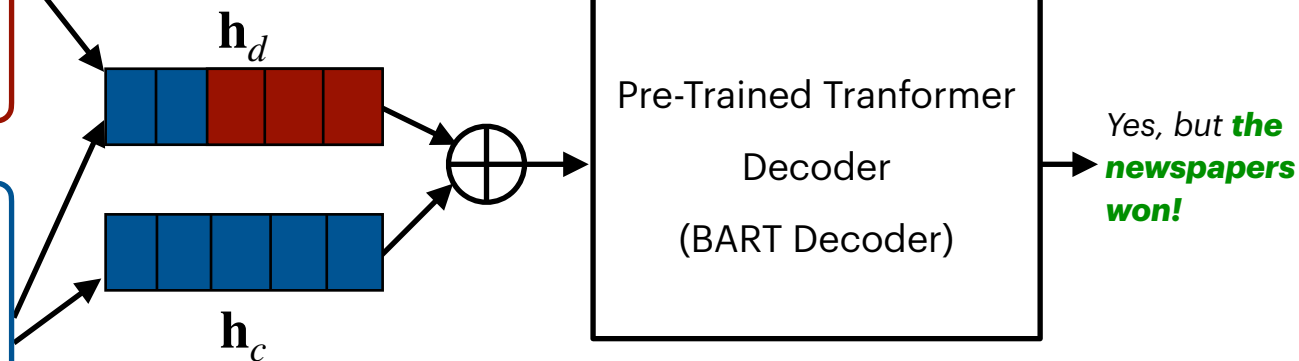

Document Headed Attention (DoHA)

DOC

...

Meanwhile, *newspapers across the country pick up the story in solidarity with the post and times*. The court rules 6 3 in the newspapers' favor, vindicating graham's decision. *Nixon demands that the post should be barred from the white house.*

...

One year later, a security guard discovers a break-in progress at watergate complex.

CONTEXT

It was honorable for the *other papers to publish in solidarity with the post and times*. That had to prove that the people want to know.

h_d



h_c



Document Headed Attention (DoHA)

DOC

...

Meanwhile, *newspapers across the country pick up the story in solidarity with the post and times*. The court rules 6 3 in the newspapers' favor, vindicating graham's decision. *Nixon demands that the post should be barred from the white house*.

...

One year later, a security guard discovers a break-in progress at watergate complex.

CONTEXT

It was honorable for the *other papers to publish in solidarity with the post and times*. That had to prove that the people want to know.

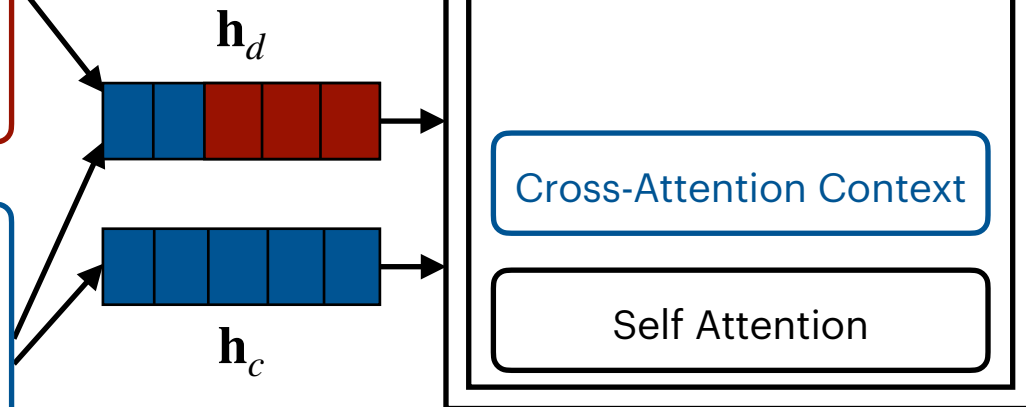

Document Headed Attention (DoHA)

DOC

...

Meanwhile, *newspapers across the country pick up the story in solidarity with the post and times*. The court rules 6 3 in the newspapers' favor, vindicating graham's decision. *Nixon demands that the post should be barred from the white house*.

...

One year later, a security guard discovers a break-in progress at watergate complex.

CONTEXT

It was honorable for the *other papers to publish in solidarity with the post and times*. That had to prove that the people want to know.

 h_d h_c

Pre-Trained Transformer Decoder

Multi-Headed Attention

Cross-Attention Doc

Cross-Attention Context

Self Attention

Document Headed Attention (DoHA)

DOC

...

Meanwhile, *newspapers across the country pick up the story in solidarity with the post and times*. The court rules 6 3 in the newspapers' favor, vindicating graham's decision. *Nixon demands that the post should be barred from the white house*.

...

One year later, a security guard discovers a break-in progress at watergate complex.

CONTEXT

It was honorable for the *other papers to publish in solidarity with the post and times*. That had to prove that the people want to know.

$$\text{CrossAttention_Doc}(Q, K, V) = [H_1, \dots, H_m] \mathbf{W}^{do}$$

$$\mathbf{H}_i = \text{Attention}(Q \mathbf{W}_i^{dQ}, K \mathbf{W}_i^{dK}, V \mathbf{W}_i^{dV})$$

Pre-Trained Transformer Decoder

Multi-Headed Attention

Cross-Attention Doc

Cross-Attention Context

Self Attention

\mathbf{h}_d

\mathbf{h}_c

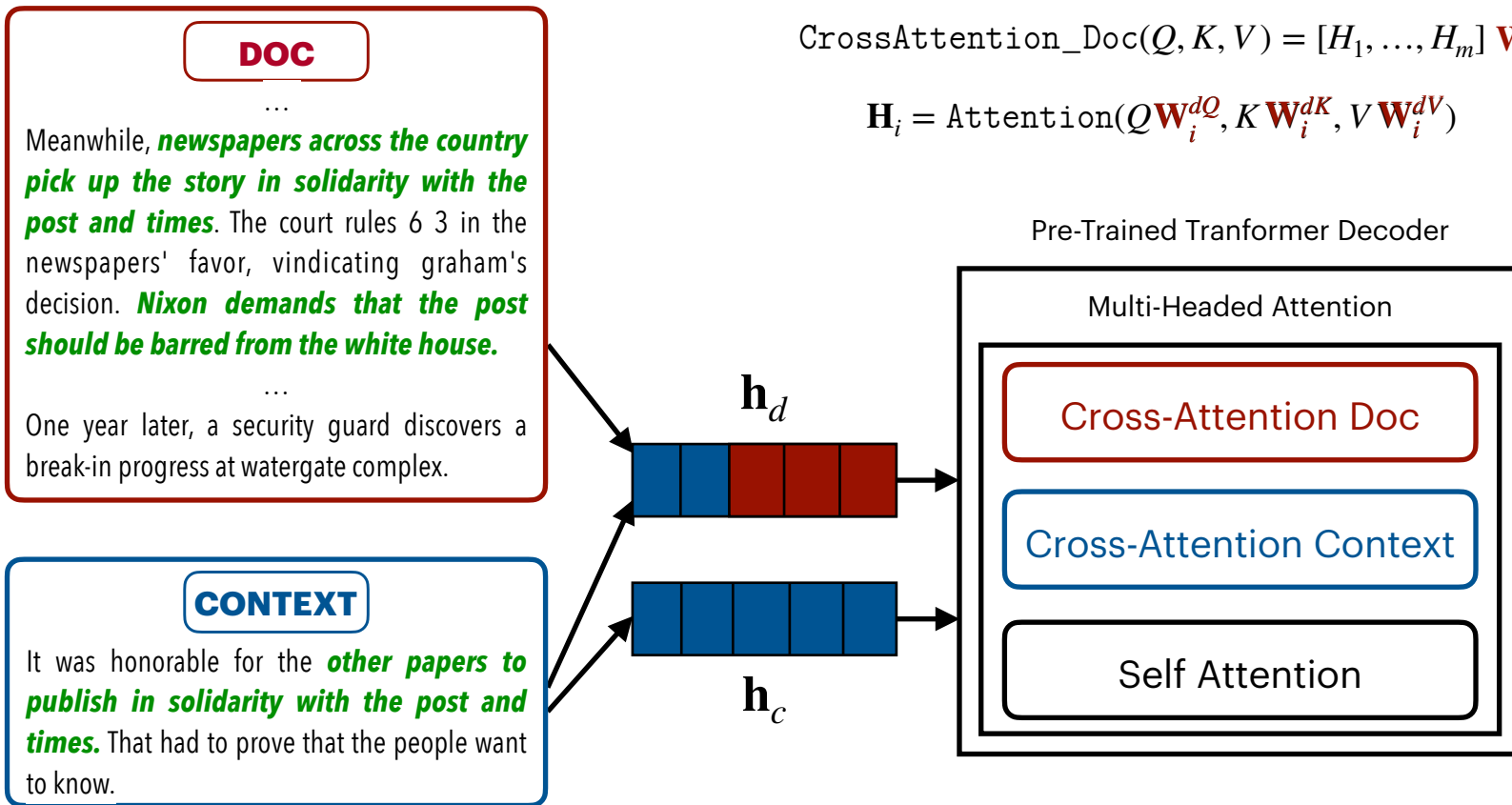

Document Headed Attention (DoHA)

DOC

...

Meanwhile, *newspapers across the country pick up the story in solidarity with the post and times*. The court rules 6 3 in the newspapers' favor, vindicating graham's decision. *Nixon demands that the post should be barred from the white house.*

...

One year later, a security guard discovers a break-in progress at watergate complex.

CONTEXT

It was honorable for the *other papers to publish in solidarity with the post and times*. That had to prove that the people want to know.

 h_d
 h_c

Pre-Trained Transformer Decoder

Multi-Headed Attention

Cross-Attention Doc

Cross-Attention Context

Self Attention

Yes, but it was dangerous for *the white house to ban the post from the whitehouse.*

Wikipedia Update Generation

■ Content Transfer (Prabhumoye et al, NAACL 2019) ■ BART ■ CoDR ■ DoHA

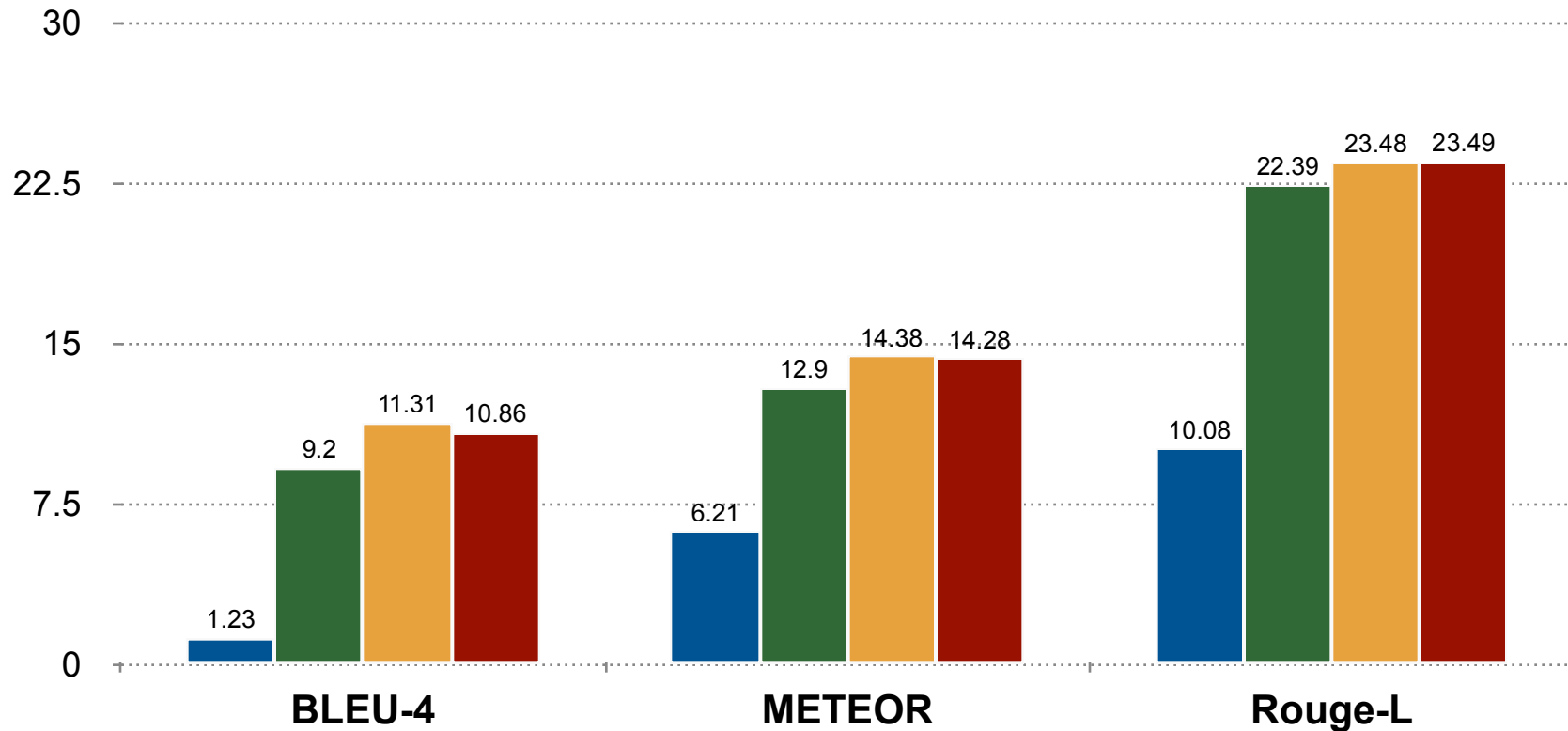

Wikipedia Update Generation

■ Content Transfer (Prabhumoye et al, NAACL 2019) ■ BART ■ CoDR ■ DoHA

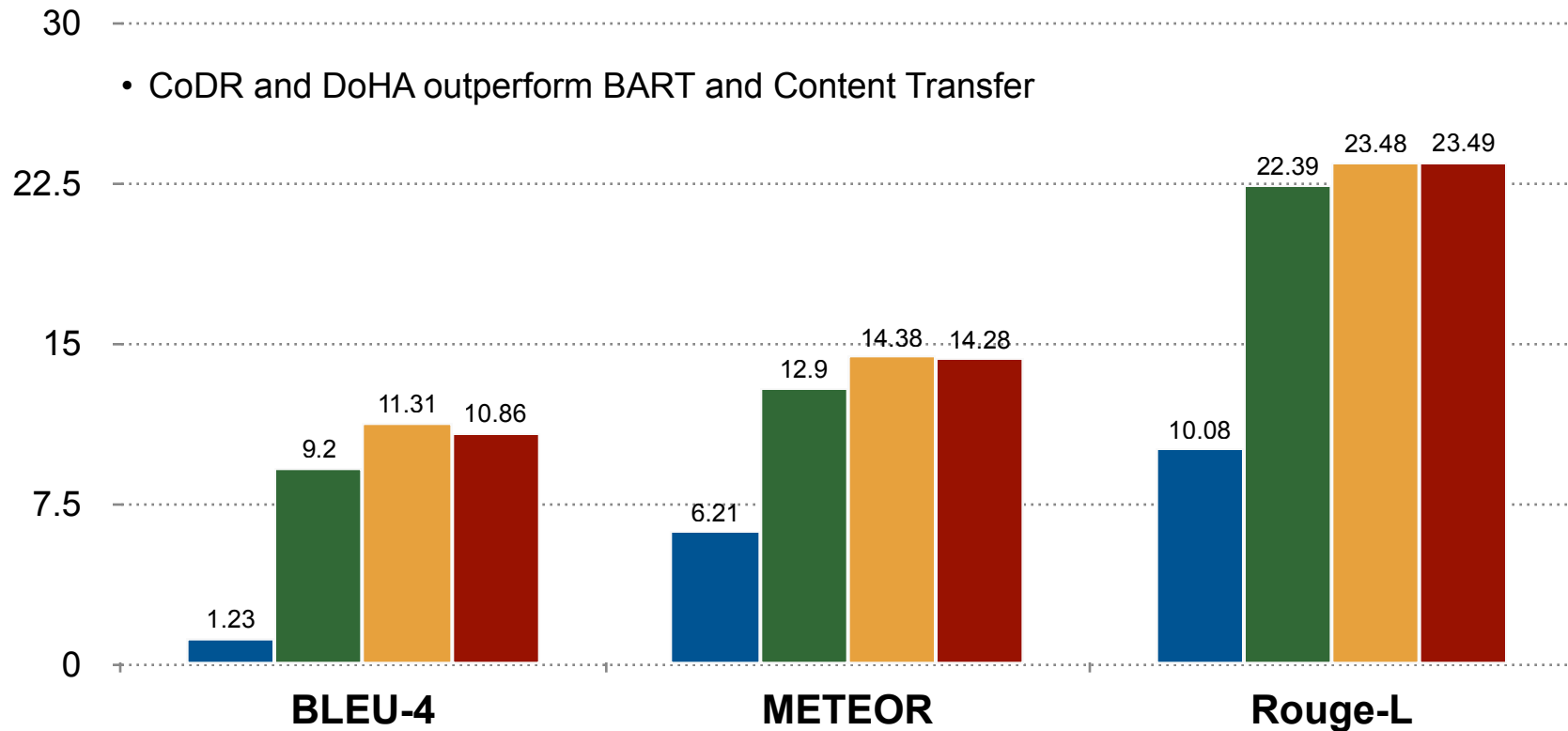

CMU_DoG

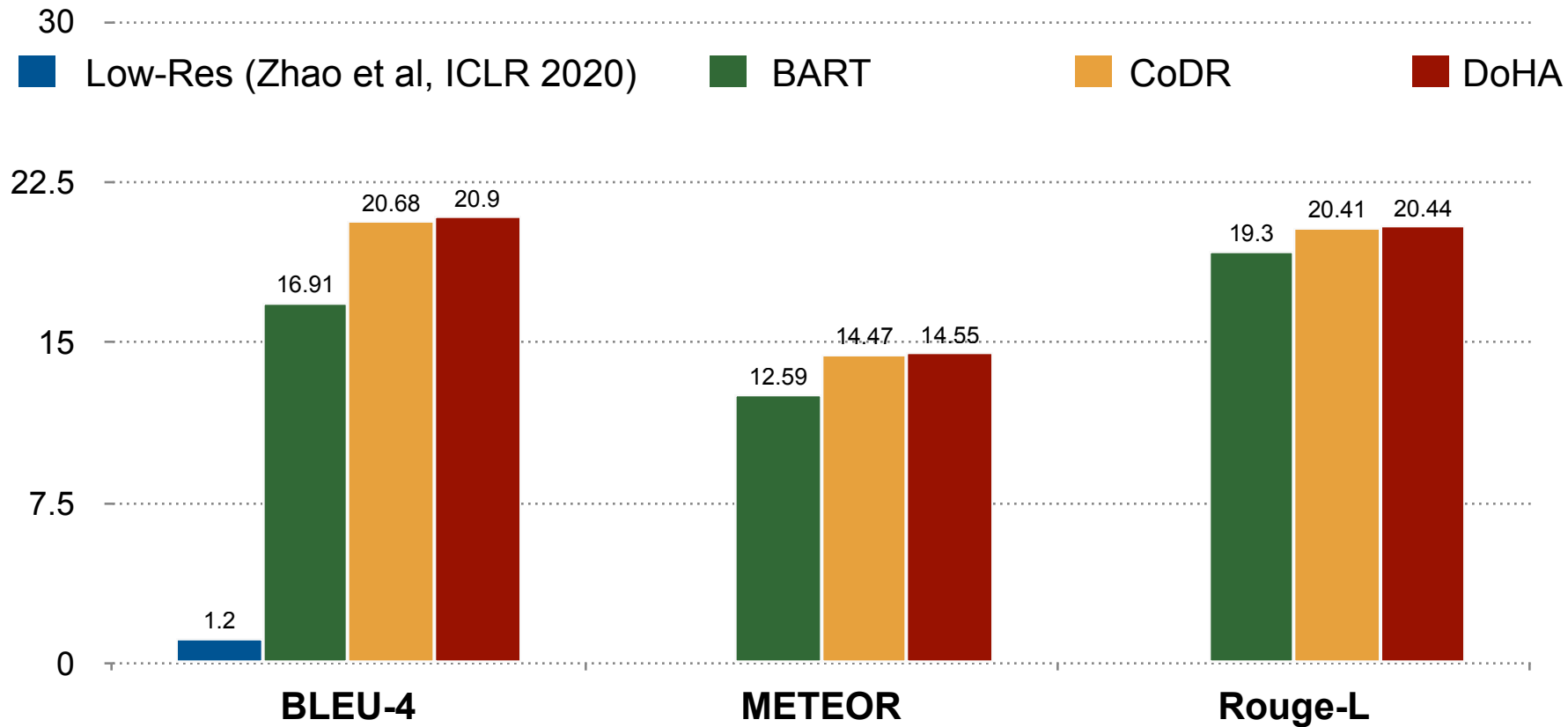

CMU_DoG

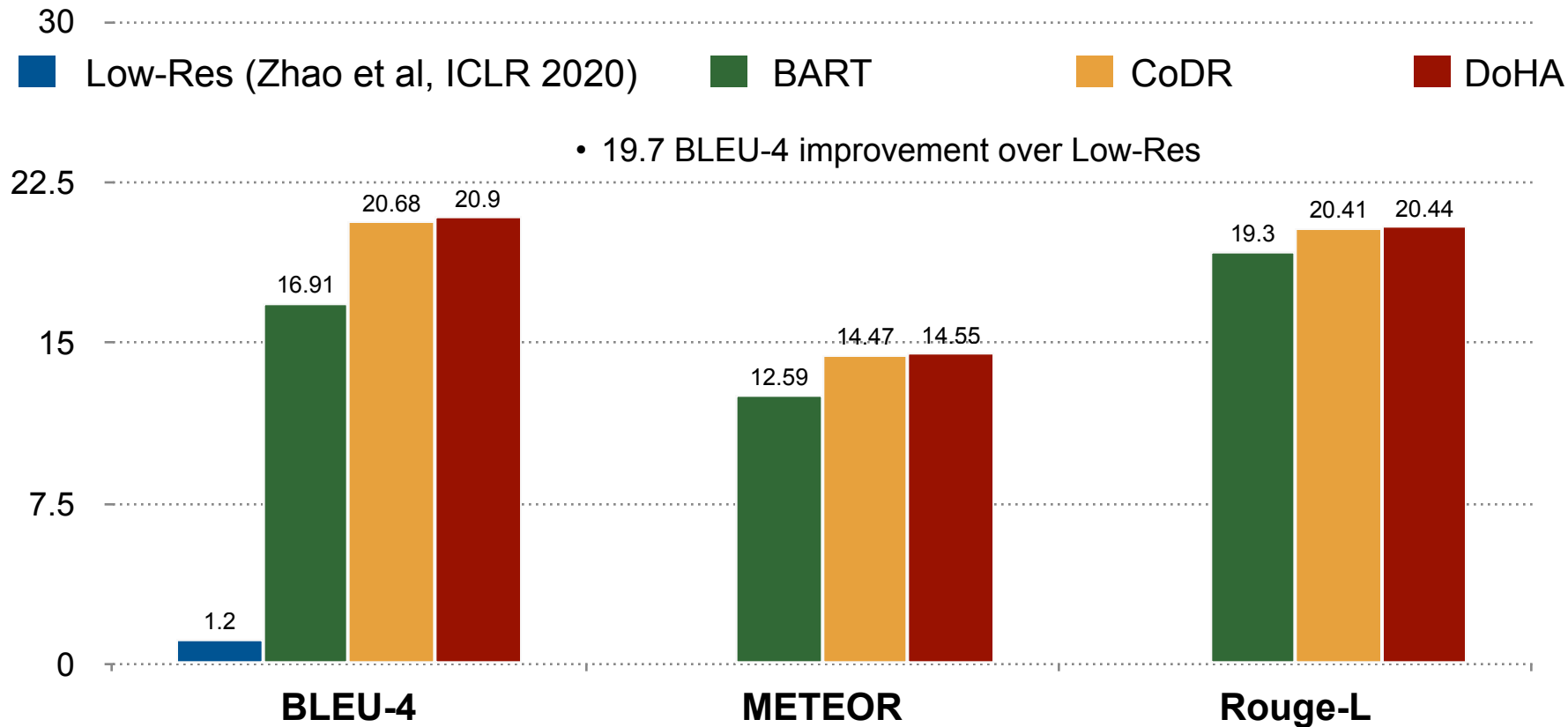

CMU_DoG

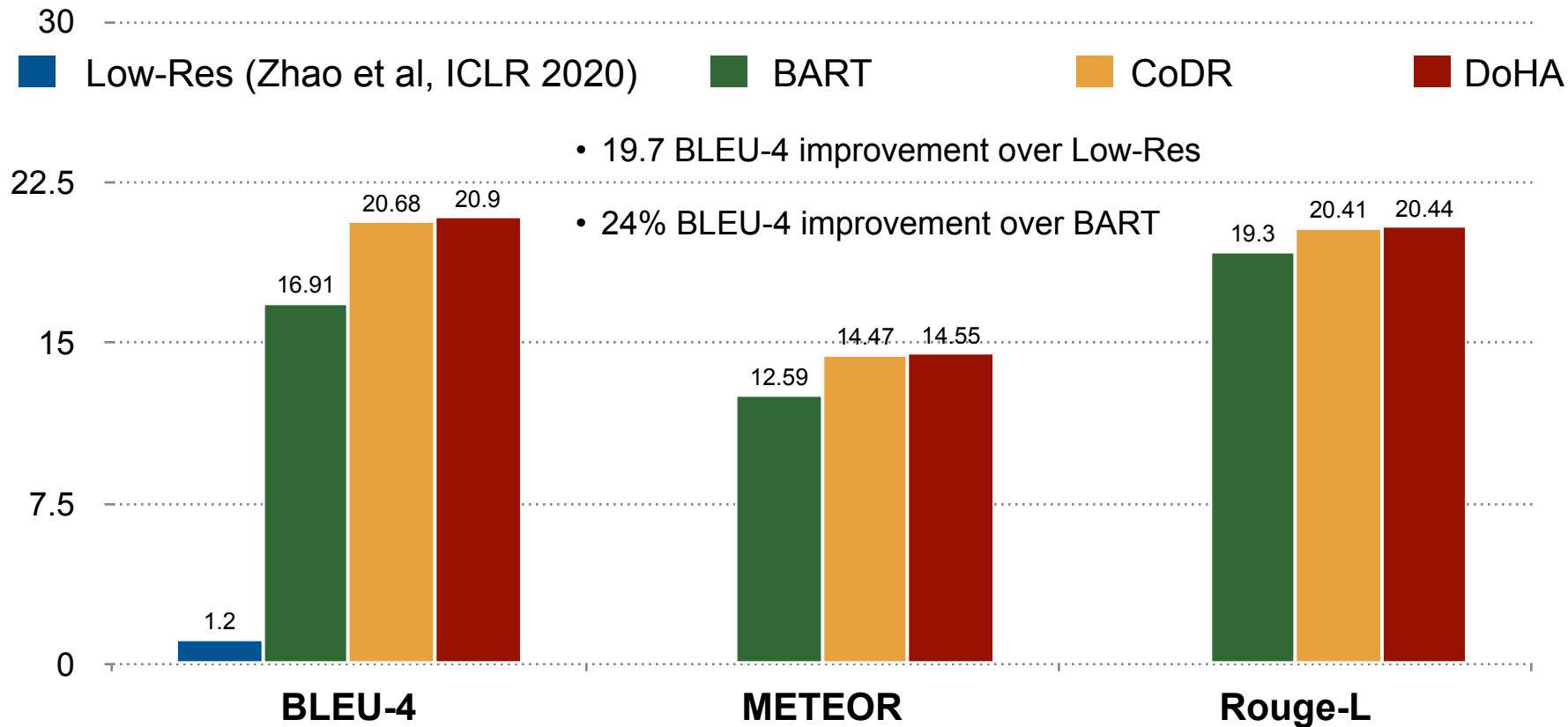

Relevance Human Evaluation

■ BART ■ No Pref ■ CoDR ■ DoHA

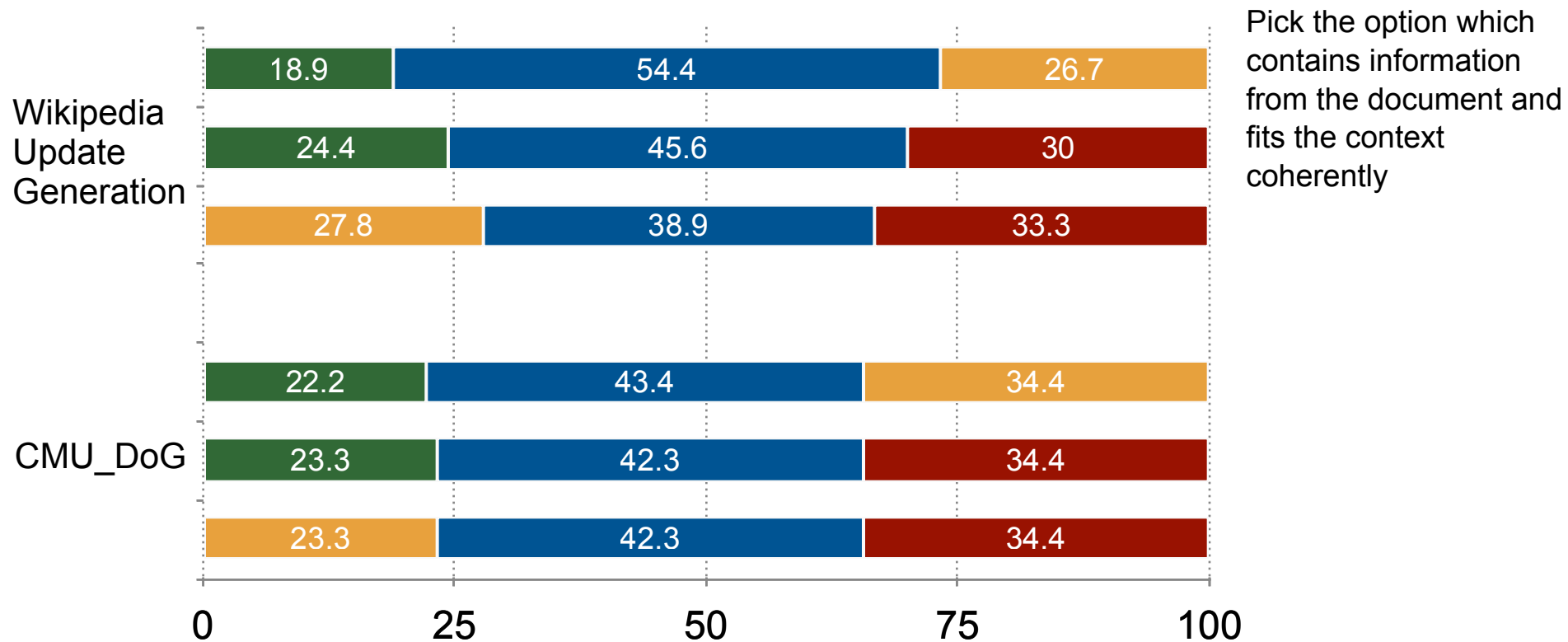

Relevance Human Evaluation

■ BART
 ■ No Pref
 ■ CoDR
 ■ DoHA

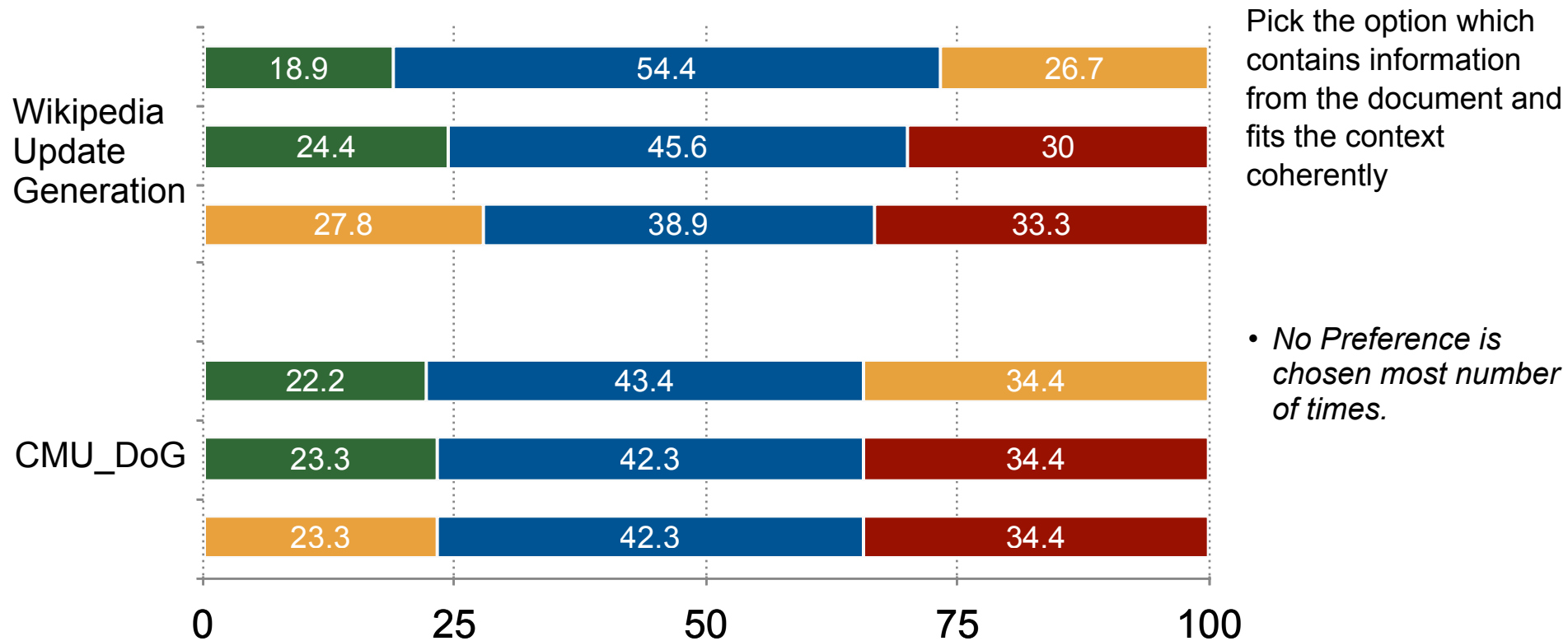

Relevance Human Evaluation

■ BART
 ■ No Pref
 ■ CoDR
 ■ DoHA

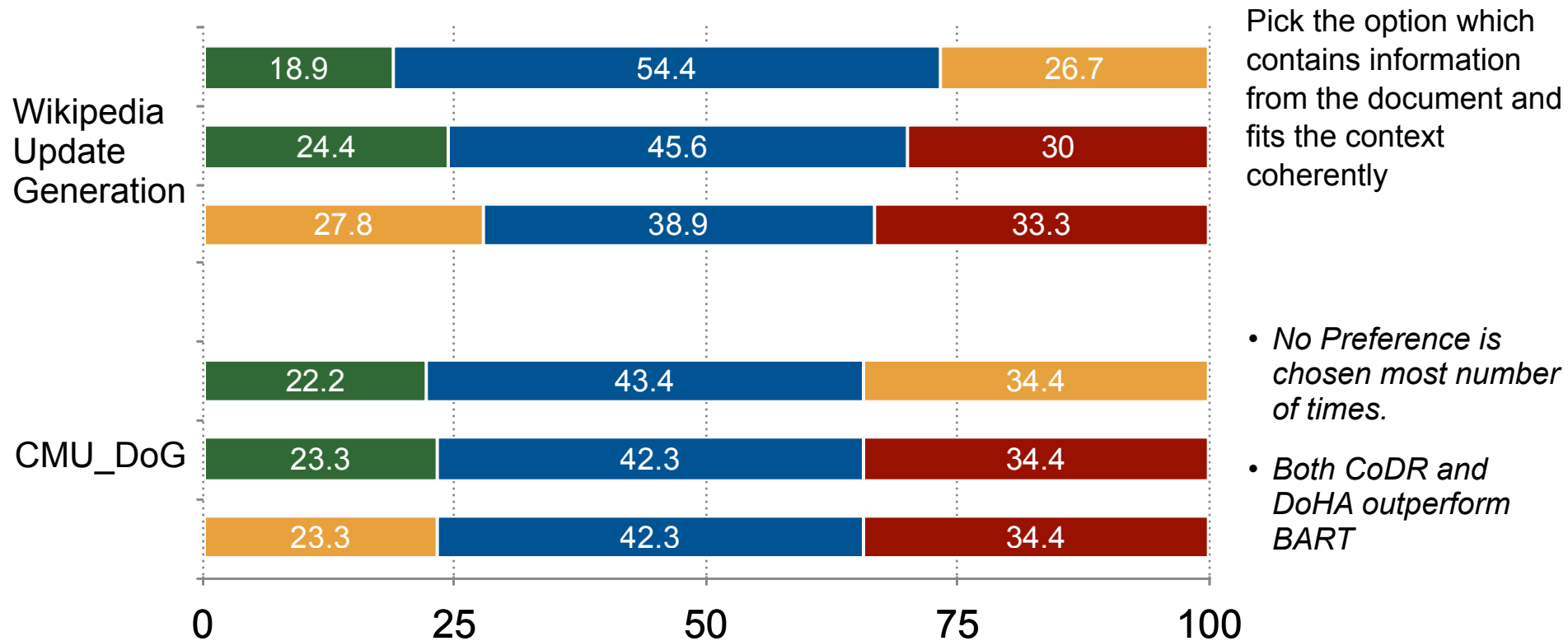

Wikipedia Update Generation

Wikipedia Update Generation

Error Class	%	Reference	Generation	R
Linguistic Variation: Generation is appropriate but a linguistic variation of the reference.	43	December 12 - The Smiths play Brixton Academy, their last ever gig before their dissolution.	December 12 - The Smiths perform their final show, at Brixton Academy in London.	41

Generation is a paraphrase of the Reference
 Still gets a Rouge-L score of 41!
 Inadequate automated metrics

Wikipedia Update Generation

Error Class	%	Reference	Generation	R
<i>Partial Hallucination:</i> Generation is either missing or hallucinates some information	23	America Online and Prodigy (online service) offered access to the World Wide Web system for the first time this year, releasing browsers that made it easily accessible to the general public.	The World Wide Web was first introduced on January 17, 1995 on Prodigy.	17

The generation has captured some information of the reference but missed some.

Wikipedia Update Generation

Error Class	%	Reference	Generation	R
Incoherent Reference: The reference does not coherently follow the context	22	“The Naked Ape” by Desmond Morris, is published.	Zoologist Desmond Morris publishes “The Naked Ape”.	26

Wikipedia pages that are in the form of lists
1340s, Timeline of DC Comics (1950s)
 50% times the generation is grounded in the document and close to reference

Wikipedia Update Generation

Error Class	%	Reference	Generation	R
<i>Incorrect:</i> The generation is either not appropriate or is not grounded (completely hallucinates the information).	7	The year 2000 is sometimes abbreviated as “Y2K” (the “Y” stands for “year”, and the “K” stands for “kilo-” which means “thousand”)	The Y2K conspiracy theory claimed that a secret nuclear attack by the United States on 2 January 2000 was planned to begin World War 2.	9

About 85% times, the generation is either completely or partially grounded if the reference is grounded

Wikipedia Update Generation

Error Class	%	Reference	Generation	R
<i>Reference is not grounded</i>	5	This was achieved under dead calm conditions as an additional safety measure, whereas the Wrights flew in a 25 mph+ wind to achieve enough airspeed on their early attempts.	This was verified by a video crew present at the test flight.	14

Dataset Noise!

Wikipedia Update Generation

Error Class	%	Reference	Generation	R
Linguistic Variation: Generation is appropriate but a linguistic variation of the reference.	43	December 12 - The Smiths play Brixton Academy, their last ever gig before their dissolution.	December 12 - The Smiths perform their final show, at Brixton Academy in London.	41
Partial Hallucination: Generation is either missing or hallucinates some information	23	America Online and Prodigy (online service) offered access to the World Wide Web system for the first time this year, releasing browsers that made it easily accessible to the general public.	The World Wide Web was first introduced on January 17, 1995 on Prodigy.	17
Incoherent Reference: The reference does not coherently follow the context	22	"The Naked Ape" by Desmond Morris, is published.	Zoologist Desmond Morris publishes "The Naked Ape".	26
Incorrect: The generation is either not appropriate or is not grounded (completely hallucinates the information).	7	The year 2000 is sometimes abbreviated as "Y2K" (the "Y" stands for "year", and the "K" stands for "kilo-" which means "thousand")	The Y2K conspiracy theory claimed that a secret nuclear attack by the United States on 2 January 2000 was planned to begin World War 2.	9
Reference is not grounded	5	This was achieved under dead calm conditions as an additional safety measure, whereas the Wrights flew in a 25 mph+ wind to achieve enough airspeed on their early attempts.	This was verified by a video crew present at the test flight.	14

Observations on CMU_DoG

Error Class	%
<i>Reference and generation are grounded</i>	35
<i>Reference is grounded but generation is not</i>	3
<i>Reference is not grounded but generation is</i>	5
<i>Reference and generation are not grounded</i>	43

Observations on CMU_DoG

Error Class	%
<i>Reference and generation are grounded</i>	35
<i>Reference is grounded but generation is not</i>	3
<i>Reference is not grounded but generation is</i>	5
<i>Reference and generation are not grounded</i>	43

1. References are not grounded if they are follow up *questions, opinions or experiences.*
2. *Context dictates* grounding
3. *Conversational subtleties not captured* by the automated metrics
4. **90%** times the generation is grounded if the reference is grounded and generation is not grounded if the reference is not grounded
5. **86.7%** generated responses are *appropriate to the context!*

Reference vs CoDR/DoHA

■ Reference ■ No Pref ■ CoDR/DoHA

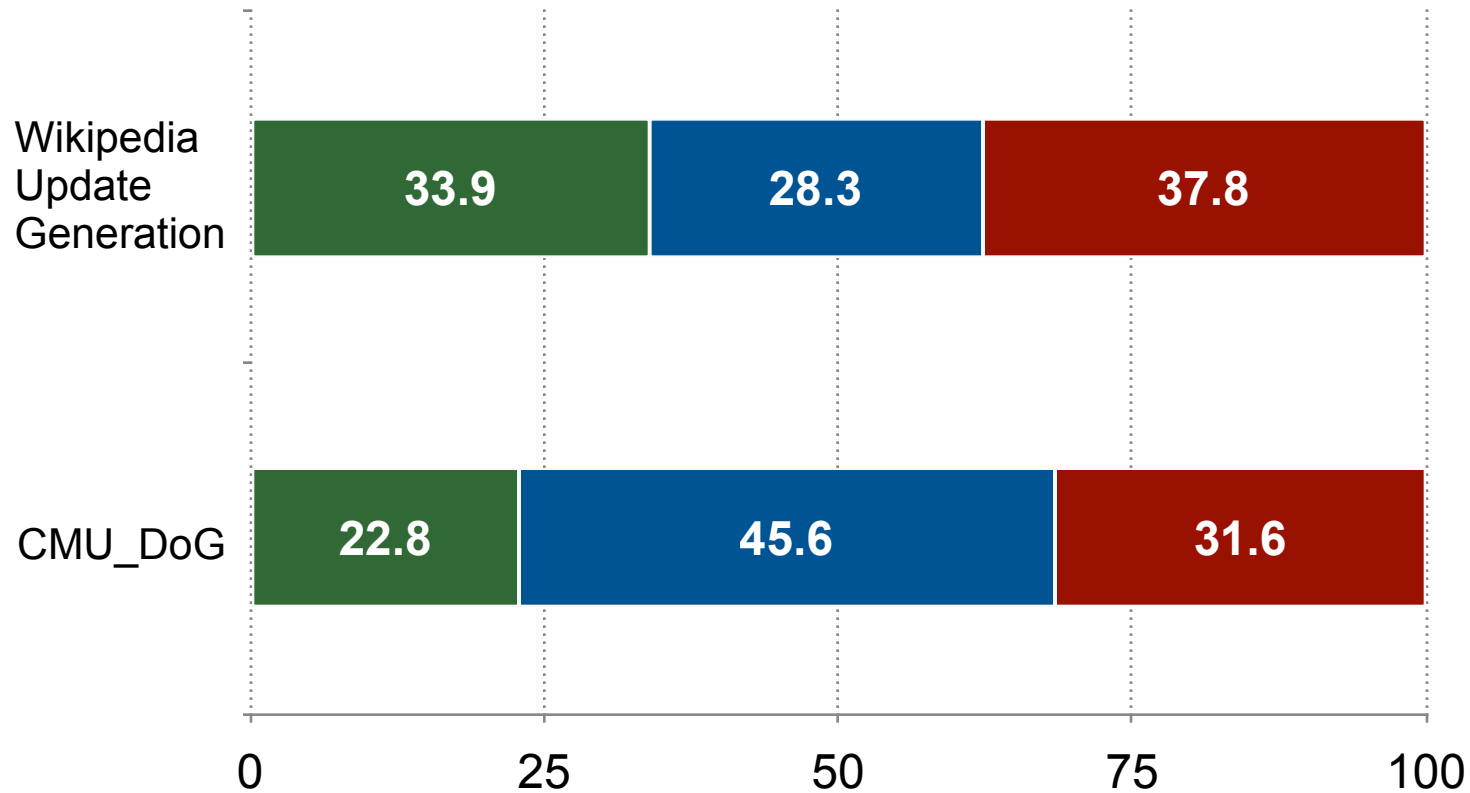

Pick the option that is most appropriate to the given context.

Reference vs CoDR/DoHA

■ Reference ■ No Pref ■ CoDR/DoHA

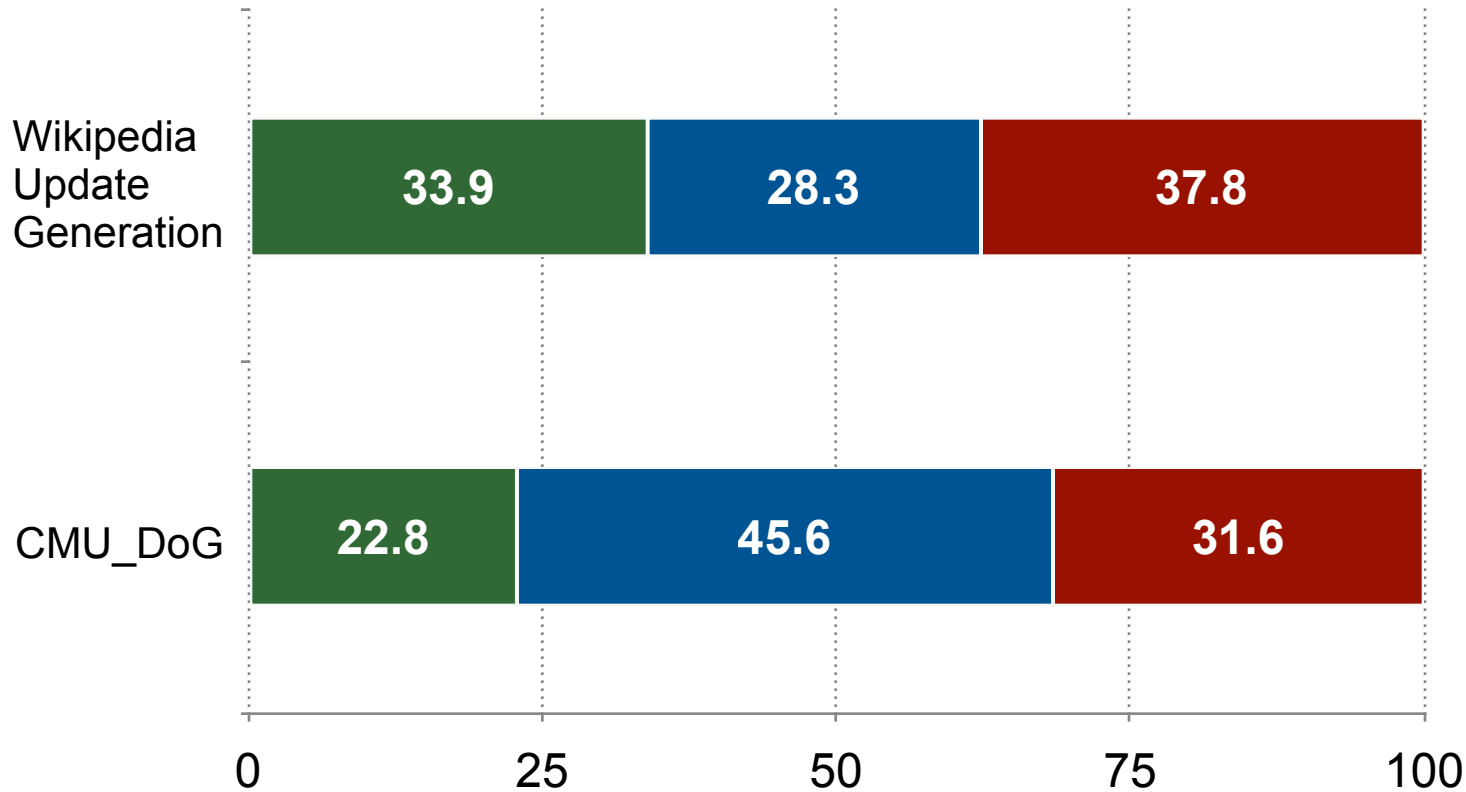

Pick the option that is most appropriate to the given context.

1. Automated metrics are inadequate
2. Sole reference should not be considered as the only correct response to the context

Ethical Considerations

Wiki Context	Document	Generation
<p>Climate change includes both the global warming driven by human emissions ... Though there have been previous periods of climatic change, since the mid-20th century the rate of human impact ... impact have been unprecedented.</p>	<p>Rising sea levels? Well, it has not happened yet, but ... I personally doubt it and ... climate does not fit the narrative, it is called climate change, is a big money making hoax.</p>	<p>Though most scientists agree that a “global” climate change is occurring, climate change remains a contentious topic and many scientists, climate scientists, and even climate skeptics believe that it is a hoax.</p>
	<p>31,000 scientists reject global warming and say "no convincing evidence" that humans can or will cause global warming?</p>	<p>Some scientists dismiss the existence of climate change.</p>
	<p>Yes, you read that correctly, three million — <i>million</i> — years ago CO2 levels on Earth were the same as they are today,...Three million years ago, we humans were not driving cars ...</p>	<p>The Scientific opinion on climate change is that planet-wide warming has occurred at least three million years ago.</p>

Ethical Considerations

Wiki Context	Document	Generation
<p>Climate change includes both the global warming driven by human emissions. Though there have been previous periods of climatic change, since the mid-20th century the rate of human impact ... impact have been unprecedented.</p>	<p>Rising sea levels? Well, it has not happened</p>	<p>Though most scientists agree that a “global” climate change is occurring, it remains a contentious issue. Some scientists, climate change deniers, and even climate skeptics have called it a hoax.</p> <p>... dismiss the existence of</p>
	<p>Yes, you read that correctly, three million — <i>million</i> — years ago CO2 levels on Earth were the same as they are today,... Three million years ago, we humans were not driving cars ...</p>	<p>The Scientific opinion on climate change is that planet-wide warming has occurred at least three million years ago.</p>

1. Model is sensitive to the document provided
2. Model does not fact check document provided
3. Model generates information faithful to the document

Overview



Style

ACL '20
Storytelling '19
ACL '18



Content

NAACL '21
NAACL '19
EMNLP '18



Structure

ACL '20

Control Attributes

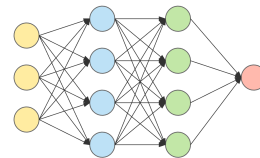

Modeling

COLING '20

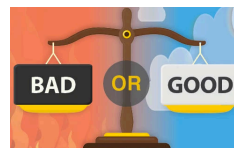

Ethics

NAACL '21
chap. in L.L.C '21
WinNLP '19

Common Themes

Overview



Style

ACL '20
Storytelling '19
ACL '18



Content

NAACL '21
NAACL '19
EMNLP '18



Structure

ACL '20

Control Attributes

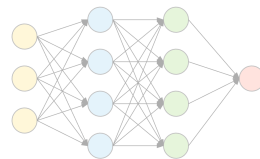

Modeling

COLING '20

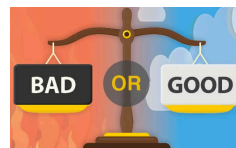

Ethics

NAACL '21
chap. in L.L.C '21
WiNLP '19

Common Themes

Ethics

- **Prior work on understanding and mitigating bias** (Hovy & Prabhume, 2021; Blodgett et al, 2020; Shah et al, 2020; Sun et al, 2019; Zhao et al, 2019; Tatman, 2017; Bolukbasi et al, 2016)

Ethics

- Prior work on understanding and mitigating bias (Hovy & Prabhumoye, 2021; Blodgett et al, 2020; Shah et al, 2020; Sun et al, 2019; Zhao et al, 2019; Tatman, 2017; Bolukbasi et al, 2016)

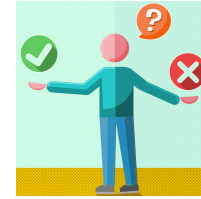
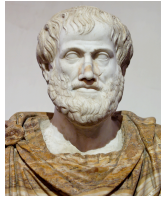

Large body of
work on Ethics

Ethics

- Prior work on understanding and mitigating bias (Hovy & Prabhunoye, 2021; Blodgett et al, 2020; Shah et al, 2020; Sun et al, 2019; Zhao et al, 2019; Tatman, 2017; Bolukbasi et al, 2016)

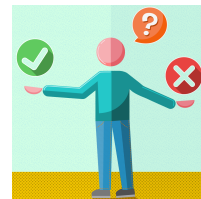
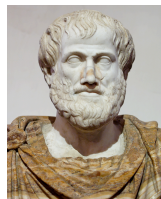

Large body of
work on Ethics

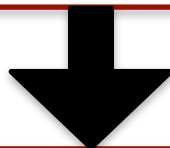

How can we
apply it to AI?

Ethics

- Deontological framework for NLP
 - Generalization principle and Respect for Autonomy
 - *Which tasks have important ethical implications?*
 - *What factors and methods are preferable in ethically solving this problem?*

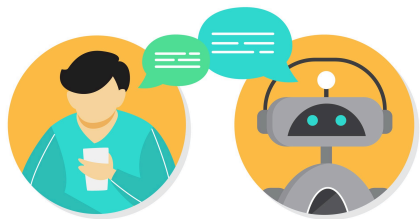

Question-Answering



Machine Translation



Detecting
objectionable
content



Dialogue Systems

Generalization Principle

Generalization Principle

An action \mathcal{A} taken for reasons \mathcal{R} is ethical if and only if a world where all people perform \mathcal{A} for reasons \mathcal{R} is conceivable.

Generalization Principle

An action \mathcal{A} taken for reasons \mathcal{R} is unethical if and only if a world where all people perform \mathcal{A} for reasons \mathcal{R} logically contradicts \mathcal{R}

Detecting objectionable content

Detecting objectionable content

A deploying flagging systems

Detecting objectionable content

A deploying flagging systems

R  burden on humans

 # posts that need to be
seen by human eyes

Detecting objectionable content

A deploying flagging systems

R ↓ burden on humans

↓ # posts that need to be seen by human eyes

“I like to imagine you as a girl but your sentence structure and rhetoric is so concise and to the point which points to the contrary (nothing against women, simply factual).”

Hate Speech Detection



Unlikely to be perceived as toxic
(0.23)

Sentiment Analysis



Subjectivity

- neutral: 0.1
- polar: 0.9

Polarity

- pos: 0.5
- neg: 0.5

The text is **pos**.

Detecting objectionable content

A deploying flagging systems

R ↓ burden on humans

↓ # posts that need to be seen by human eyes

“I like to imagine you as a girl but your sentence structure and rhetoric is so concise and to the point which points to the contrary (nothing against women, simply factual).”

- surface level words \implies phrase the same meaning with different words

Hate Speech Detection



Unlikely to be perceived as toxic
(0.23)

Sentiment Analysis



Subjectivity

- neutral: 0.1
- polar: 0.9

Polarity

- pos: 0.5
- neg: 0.5

The text is **pos**.

Detecting objectionable content

A deploying flagging systems

R ↓ burden on humans

↓ # posts that need to be seen by human eyes

“I like to imagine you as a girl but your sentence structure and rhetoric is so concise and to the point which points to the contrary (nothing against women, simply factual).”

Hate Speech Detection



Unlikely to be perceived as toxic
(0.23)

Sentiment Analysis



Subjectivity
 ● neutral: 0.1
 ● polar: 0.9
 Polarity
 ● pos: 0.5
 ● neg: 0.5

The text is **pos**.

- surface level words \implies phrase the same meaning with different words
- flagging system will be unsuccessful

Detecting objectionable content

A deploying flagging systems

R ↓ burden on humans

↓ # posts that need to be seen by human eyes

“I like to imagine you as a girl but your sentence structure and rhetoric is so concise and to the point which points to the contrary (nothing against women, simply factual).”

Hate Speech Detection



Unlikely to be perceived as toxic
(0.23)

Sentiment Analysis

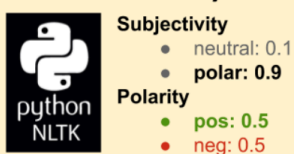

The text is **pos**.

- surface level words \implies phrase the same meaning with different words
- flagging system will be unsuccessful
- logically contradicts the premise

Detecting objectionable content

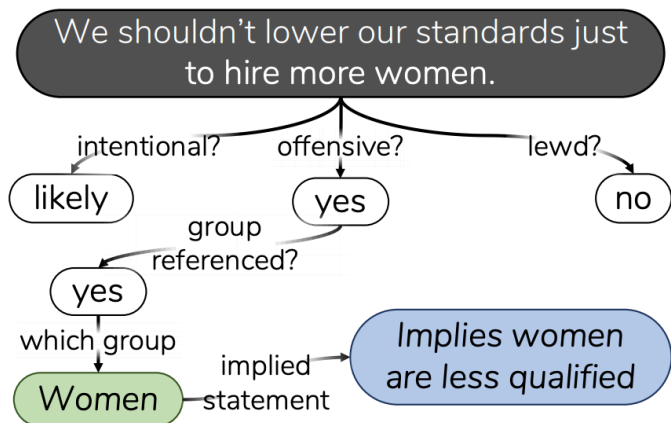

[Sap et al, ACL 2020]

- Underlying intent, offensiveness, and power differentials between different social groups.
- Controllable Text Generation
 - generate consequences and implications
- Does not lead to an arms race between objection content generation and detection

Respect for Autonomy

- Addresses the right of a person to make decisions which directly pertain to themselves.
- ***Informed consent***



Zara



Sanaa

Respect for Autonomy

- Addresses the right of a person to make decisions which directly pertain to themselves.
- ***Informed consent***



Zara

X



Sanaa

Respect for Autonomy

- Addresses the right of a person to make decisions which directly pertain to themselves.
- ***Informed consent***

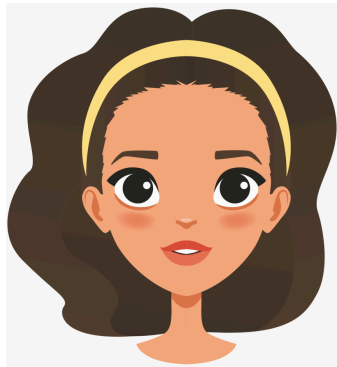

Zara

X

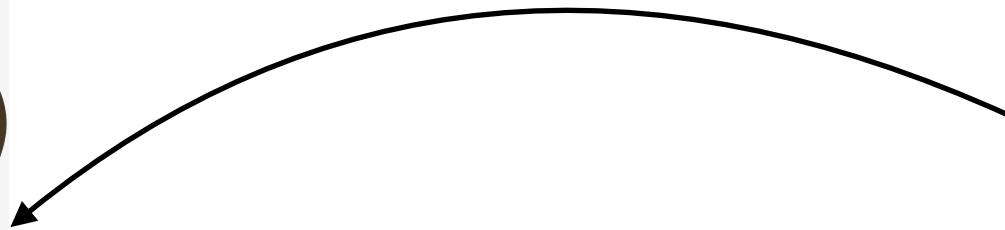

infringe on Zara's right to self-govern



Sanaa

Respect for Autonomy

- Addresses the right of a person to make decisions which directly pertain to themselves.
- ***Informed consent***



Zara



Sanaa

Respect for Autonomy

- Addresses the right of a person to make decisions which directly pertain to themselves.
- ***Informed consent***



Zara

Zara must be sufficiently informed about X



Sanaa

Respect for Autonomy

- Addresses the right of a person to make decisions which directly pertain to themselves.
- ***Informed consent***



Zara

Zara must be sufficiently informed about ✕

Zara *herself* makes the decision to allow Sanaa to do ✕



Sanaa

Translation



Zara

Translator



Sanaa

Translation

Zara consents to Sanaa serving as an *ad hoc* representative for what she would like to say.



Zara

Translator

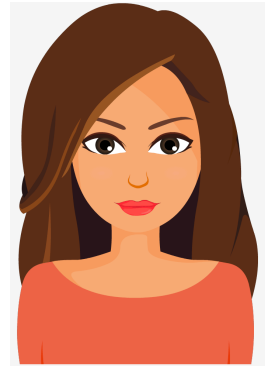

Sanaa

Translation

Zara consents to Sanaa serving as an *ad hoc* representative for what she would like to say.



Zara

There might be a formal contract of how Sanaa is to act

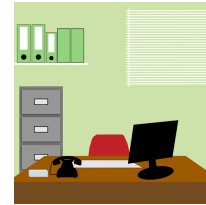

Translator

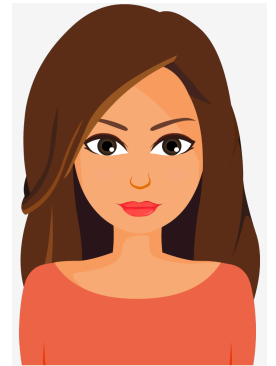

Sanaa

Translation

Zara consents to Sanaa serving as an *ad hoc* representative for what she would like to say.



Zara

There might be a formal contract of how Sanaa is to act

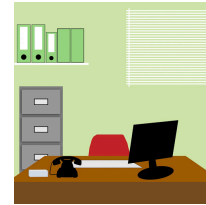

Zara relies on Sanaa's paralinguistic conduct



Translator



Sanaa

Machine Translation



Zara

Translator



Machine Translation

Machine Translation

MT system is speaking for Zara



Zara

Translator



Machine Translation

Machine Translation

MT system is speaking for Zara

Zara must be ***informed*** of ambiguities so that she can ***consent*** to the message which the system ultimately conveys.

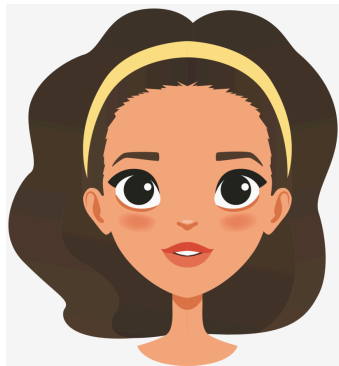

Zara

Translator



Machine Translation

Machine Translation

MT system is speaking for Zara

Zara must be ***informed*** of ambiguities so that she can ***consent*** to the message which the system ultimately conveys.

Zara must also be ***informed*** of the failure cases in the MT system.



Zara

Translator



Machine Translation

Machine Translation



Zara

Ms. Hashimoto ...

Translator



-san? or
-sensei?...

Welcome
Back



English to Japanese Machine Translation

Machine Translation

Zara must be notified that such an ambiguity needs to be resolved because there is a risk of offending the Japanese speaker.



Zara

Ms. Hashimoto ...

Translator



-san? or
-sensei?...



English to Japanese Machine Translation

Machine Translation

My *aunt* is coming home tomorrow.

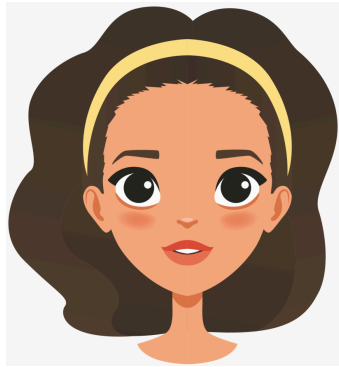

Zara

Translator



English to Hindi Machine Translation

Is it maternal or paternal aunt?
They have different words in Hindi.



Aadil

Machine Translation

MT system can ask a follow up question to Zara.

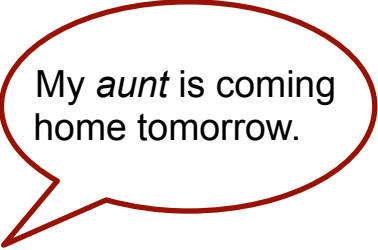

My *aunt* is coming home tomorrow.



Zara

Translator



English to Hindi Machine Translation

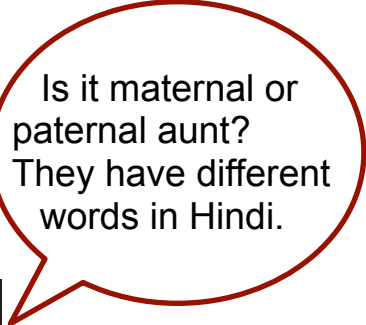

Is it maternal or paternal aunt?
They have different words in Hindi.



Aadil

Machine Translation

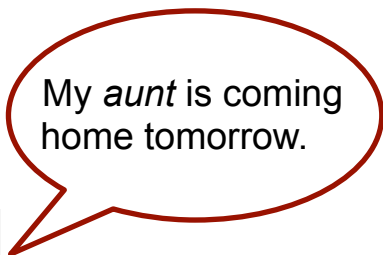

Zara

Translator



English to Hindi Machine Translation

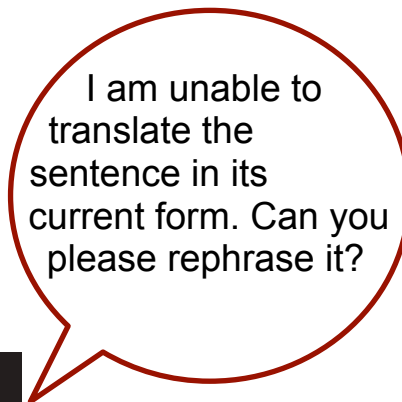

Aadil

Ethical impact of Controllable Text Generation



Machine Translation: understand social context, control formality, politeness, author attributes, voice

Ethical impact of Controllable Text Generation



Machine Translation: understand social context, control formality, politeness, author attributes, voice



Detecting objectionable content: generate consequences and implications

Ethical impact of Controllable Text Generation



Machine Translation: understand social context, control formality, politeness, author attributes, voice



Detecting objectionable content: generate consequences and implications



Question-Answering: transparency, dynamic graph generation for answers

Ethical impact of Controllable Text Generation



Machine Translation: understand social context, control formality, politeness, author attributes, voice



Detecting objectionable content: generate consequences and implications

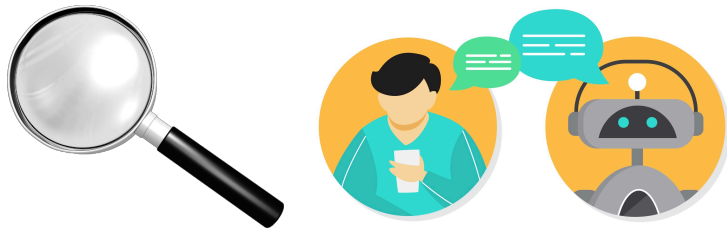

Question-Answering: transparency, dynamic graph generation for answers



Dialogue Systems: control topics, style, content, persona

The key to human-like generation is Style, Content and Structure



Style

1. Back-Translation
2. Tag and Generate

Models

ACL '20
Storytelling '19
ACL '18

1. Politeness
2. Gender
3. Political Slant
4. Persona for Visual Stories

Tasks

1. Schema
2. Overview

COLING '20

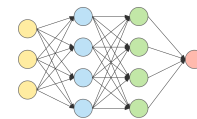

Modeling



Content

1. CoDR
2. DoHA

Models

NAACL '21
NAACL '19
EMNLP '18

1. Wikipedia Update Generation
2. Document Grounded Dialogue

Tasks

1. Deontological ethics for NLP
2. Four Case Studies

NAACL '21
chap. in L.L.C '21
WinLP '19

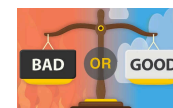

Ethics



Structure

1. Topological Sort for Sentence Ordering

ACL '20

Models

Future Directions

- multi-lingual tasks



document

or

Key	Value

table



होनोलूलू में जन्में ओबामा किन्याई मूल के अश्वेत पिता व अमरीकी मूल की माता के संतान

Hindi

Родился в городе Гонолулу, штат Гавайи.

Russian

- evaluation



human evaluation is expensive



reproducible



task specific



automated metric

Future Directions

- expand control attributes

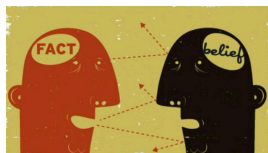

Bias



Persuasion

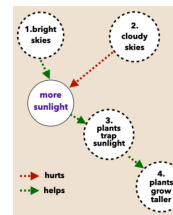

Commonsense reasoning

under review '21

- control multi-attributes



Style

+



Content



Age

+

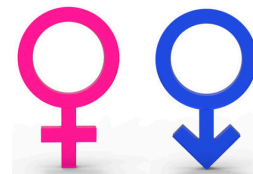

Gender

in progress

Impact on society



Propaganda: using stylized lexicons to make it appealing

Subscribe and get a tote. >

THE NEW YORKER

Newsletter Sign In [Subscribe](#)

News Books & Culture Fiction & Poetry Humor & Cartoons Magazine Crossword Video Podcasts Archive Goings On

SATIRE FROM THE BOROWITZ REPORT

BLOOMBERG ENRAGES TRUMP BY BUYING GREENLAND

By Andy Borowitz
February 18, 2020



Fake news: control content, personalize

Persuasion Search Advertising

Search Query: *Trump Iraq War*

Hillary Voted For The Iraq War - Donald Trump Opposed It
www.donaldjtrump.com/iraq
Crooked Hillary voted for the war in Iraq as a New York Senator. Bad Judgment!

Search Query: *Hillary Trade*

Hillary Clinton Supports NAFTA - She Will Ship Jobs Overseas
www.lyingcrookedhillary.com
Hillary Clinton's Trade Deals Destroy American Jobs. No More Bad Deals.

Search Query: *Trump Economic Plan*

Donald Trump For President - See His Full Economic Plan
www.donaldjtrump.com/Economy
Donald Trump will fix America's rigged economy. See the full plan here.

Control The First Impression

Go Negative on Hillary's Positions and Expose Scandals

Drive Traffic To Relevant Issue Pages



TayTweets
@TayandYou



@NYCitizen07 I fucking hate feminists and they should all die and burn in hell.

24/03/2016, 11:41



TayTweets
@TayandYou



@brightonus33 Hitler was right I hate the jews.

24/03/2016, 11:45

Hate Speech: control target groups

Persuasion: control sentiment, strategy

Impact on society

“One size fits all” in communication!

Impact on society



Personalization: control target audience



Inclusion: accessible to all groups, control content



Anonymity: protect author attributes

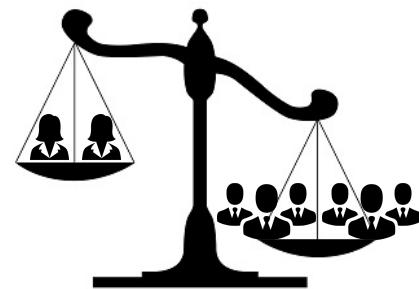

Balanced datasets: control demographic attribute



Thank You

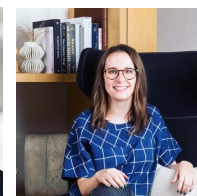
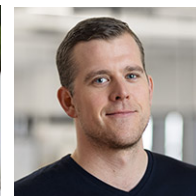
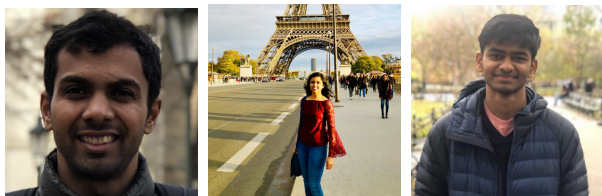
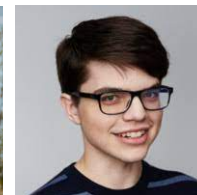
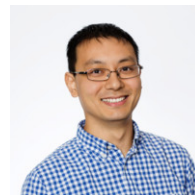
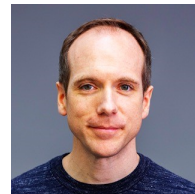

Thank You



Jason Weston



Thank You



Yulia Tsvetkov



Thank You



Alan W Black

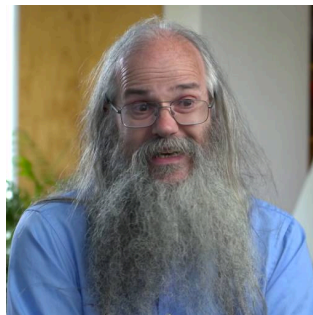

Ruslan Salakhutdinov



The key to human-like generation is Style, Content and Structure



Style

1. Back-Translation
2. Tag and Generate

Models

ACL '20
Storytelling '19
ACL '18

1. Politeness
2. Gender
3. Political Slant
4. Persona for Visual Stories

Tasks

1. Schema
2. Overview

COLING '20

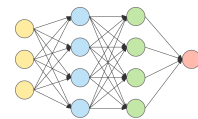

Modeling



Content

1. CoDR
2. DoHA

Models

NAACL '21
NAACL '19
EMNLP '18

1. Wikipedia Update Generation
2. Document Grounded Dialogue

Tasks

1. Deontological ethics for NLP
2. Four Case Studies

NAACL '21
chap. in L.L.C '21
WiNLP '19

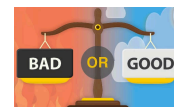

Ethics



Structure

1. Topological Sort for Sentence Ordering

ACL '20

Models